

# THE PROBLEM OF CURRENT CHANNELLING: A CRITICAL REVIEW

ALAN G. JONES

*Geophysics Laboratory, Physics Department, University of Toronto, Toronto, Ontario, Canada, M5S 1A7*

**Abstract.** The notion that currents induced 'elsewhere', by external source fields, could wend their way in a frequency-independent ohmic-like manner through a region of interest has been the cause of many recent disputes within the geomagnetic induction community. In particular, two-dimensional (2D) models of the Rhinegraben, and of the region known as the 'Eskdalemuir anomaly' in southern Scotland, have been dismissed as erroneous by those who believe that the observations are more correctly interpreted as due to the effects of 'channelled' currents rather than 'induced' currents. In this review, attention is paid primarily to consider under what circumstances any perturbation of current flow, which may manifest itself as a 'DC-like' channelled current, could cause a 'problem' for those wishing to interpret their observations. Various concepts are introduced, particularly the ratio of 3D/2D current channelling numbers for the induction problem, which is shown to be the ratio of the length of the 3D body to the skin depth in the host medium. It is stressed that the worker must analyse his data by adequate statistical techniques, and that the simplest physical models possible, that describes the observations, must be sought. Finally, suggestions are made for further work to be undertaken.

## 1. Introductory Remarks

There are a growing plethora of expressions that attempt to describe varying aspects of one particular physical phenomenon which occurs in electromagnetic investigations of the Earth's crust – either on very small scales, such is of interest to the prospecting community, through the whole spectrum to the largest scale of all, global studies. This phenomenon is the re-arrangement of field lines of current density as current – induced in the earth either artificially (controlled sources), or naturally (variations of current flow in the ionosphere) – flows from a region of one value of electrical conductivity into a region of a differing conductivity, thereby giving rise to the generation of charges on the surface separating the two regions. This phenomenon has been variously termed 'current deviation', 'current deflection', 'current gathering', 'current concentration', 'current leakage', and most often with those whose primary interest lie in natural source techniques, 'current channelling'. Certain of these expressions may be used in both two-dimensional (2D) and three-dimensional (3D) situations, whilst others, of which 'current channelling' is the prime example, clearly reserve themselves for use in only 3D situations.

It is not the purpose of this review to define which of these terms are to be employed in any given situation, but rather to consider under what circumstances any perturbation of current flow may become a 'problem'. Hence, the reviewer is in the (somewhat) fortunate position of having not to review current perturbation effects themselves, of which countless examples abound, but of reviewing cases where such effects, when postulated, lead to a questioning of the basic physical laws involved. Accordingly, it is necessary to consider 'what are current perturbation effects?', and 'when do they become a problem?'

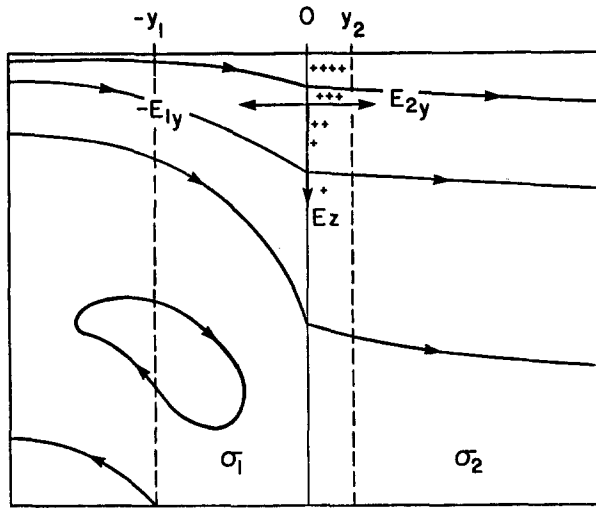

Fig. 1. Current lines and surface charge distributions near a vertical discontinuity in conductivity [redrawn from Price (1973)].

The perturbation of the flow of current by electrical conductivity discontinuities is a physical phenomenon whose existence must not be doubted. To give a simple example, which has been well treated in the published literature but which serves admirably to illustrate a current perturbation effect, consider the elementary fault model in which two quarter spaces of differing electrical conductivity are juxtaposed such that the conductivity is invariant along the  $x$ -axis (Figure 1). At any given frequency, the skin depth phenomenon dictates that at distances well away from the boundary (where 'well away' will be discussed shortly), the current induced by a uniform external source field flows closer to the surface in region 1 than it does in region 2 (assuming  $\sigma_1 > \sigma_2$ ). For the  $H$ -polarisation mode of induction, i.e., only electromagnetic field components  $H_x$ ,  $E_y$ , and  $E_z$  present, then, as discussed by Price (1973; see also Jones and Price, 1970, 1973; and Jones, 1973), there is an alternating surface charge continually being placed on the boundary by the impinging current flow. This surface charge,  $\tau$ , leads to a disparity in the normal component of the displacement field between regions 1 and 2, i.e.,

$$\Delta D_y = D_{1y} - D_{2y} = \tau, \quad (1)$$

and the rate-of-change of this disparity generates a difference in the current flow normal to the boundary,

$$\Delta J_y = J_{1y} - J_{2y} = \dot{\tau}. \quad (2)$$

This current, as can be seen in Equation (2), is of the same order of magnitude as the true displacement current, and hence can be ignored for  $\sigma \gg \omega\epsilon$ , which is true of all media and at all frequencies of geophysical interest. However, the electrostatic field in each medium associated with the surface charge  $\tau$  is not negligible as

$$E_{1y} = \varepsilon_1^{-1} \cdot D_{1y} \quad \text{and} \quad E_{2y} = \varepsilon_2^{-1} \cdot D_{2y}, \quad (3)$$

where  $\varepsilon_1$  and  $\varepsilon_2$  are the electrical permittivities in the two media and are of order  $10^{-10}$  ( $10^{-9}/4\pi$  in free space). The two fields are oppositely directed, and are equal when  $\varepsilon_1 = \varepsilon_2$ . Hence, for an applied electric field  $E_0$ , the electric field in the  $y$ -direction is reduced by  $E_{1y}$  in  $\sigma_1$ , and is increased by  $E_{2y}$  in  $\sigma_2$  ( $= E_{1y}$  for  $\varepsilon_1 = \varepsilon_2$ ). However, the boundary conditions on the tangential  $E$ -field ( $E_z$ ) at an interface demand that  $E_z$  is the same in both regions. Accordingly, the lines of electric force, and therefore also of current density, are refracted at the interface, as illustrated in Figure 1. For points outwith the two bounds  $-y_1$  and  $y_2$ , shown figuratively in Figure 1, the current flow has 'adjusted' such that it is in 'equilibrium' with that expected in a homogeneous half space of  $\sigma_1$ , for region 1, or  $\sigma_2$ , for region 2. Hence, the distances  $y_1$  and  $y_2$  may be thought of as the 'adjustment distances' or 'equilibrium distances' (more discussion of these distances will be given in a later section), and a 1D interpretation of the response function  $E_y/H_x$  observed at  $y < -y_1$  or  $y > y_2$  will yield the correct conductivity, either  $\sigma_1$  or  $\sigma_2$  respectively. However, an interpretation of  $E_y/H_x$  observed within the bounds  $-y_1 < y < y_2$  will not yield either  $\sigma_1$  or  $\sigma_2$  due to the perturbation of the current flow at the boundary.

This simple 2D illustration of a current perturbation effect can quite easily be extended to 3D. For an embedded block of differing conductivity from an otherwise uniform host, if the length of the block is such that currents flowing along its strike (the ' $E$ -polarisation' mode) have 'adjusted' to their 'equilibrium' levels at the point where a profile on the surface is undertaken, then a 2D interpretation of the data recorded over the 3D body will yield the correct conductivity structure. However, if the profile is undertaken within the 'equilibrium distance' of one of the faces of the body, or if the body is too short for the currents to reach equilibrium, then a 2D interpretation of the data will yield an incorrect conductivity structure.

Thus, we can associate the 'problem of current channelling' with the existence of minute alternating charge distributions impinged on the conductivity discontinuities, the magnetic effects of which are of the same order of magnitude as the displacement currents (Equation 2), and hence can be ignored, but whose electric fields are comparable with the other electromotive forces involved. These charges were termed by Price (1973) 'the villain of the piece' – and certainly many villainous remarks have been made within the past few years due to their notoriety.

Having identified the cause of current perturbations, the question now arises 'when do these perturbations become a problem'. Clearly, for the above example, a 'problem' occurs on attempting to interpret the  $E_y/H_x$  response within the bounds  $-y_1 < y < y_2$  in a 1D manner. In a more general 3D context, current perturbation effects become a 'problem' when a 1D or 2D interpretation is attempted on data from a 3D induction problem, or when the 3D interpretation does not consider an area sufficiently large enough to describe the regional induction effects.

An excellent example of a study where 3D induction processes have been well described by both analogue and numerical 3D models is the region around Vancouver

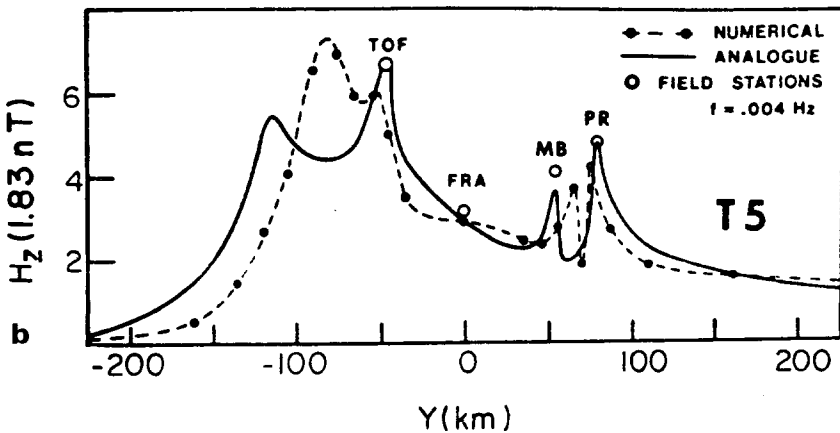
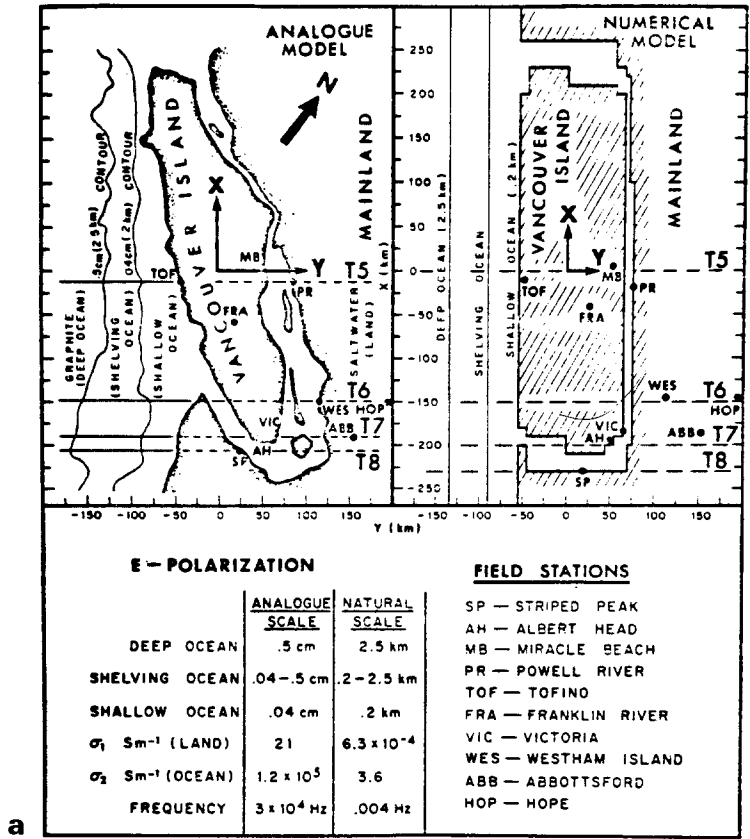

Fig. 2a. The analogue and numerical 3D models of the region around Vancouver Island, with the field stations shown; b) the numerical and analogue normalised 3D Hz values along profile T5 compared with the field data [both figures taken from Ramaswamy *et al.* (1980)].

Island. In a compelling and convincing comparison of a scale modelling experiment (Figure 2a), 3D numerical modelling by finite differences (Jones and Pascoe 1973), and field data (Figure 2b), Ramaswamy *et al.* (1980) illustrated that the field observations can all be well described by 'local' induction in the region around Vancouver Island and part of the British Columbian and northwestern U.S.A. mainland, with associated current perturbation effects around the island (see Figure 2b). Hence, I do not consider that the 'current channelling' effects here are a 'problem' – however, they certainly would have been if the field observations were not compatible with the numerical and analogue 3D models (more consideration is given to these observations in the Conclusions).

This leads, quite naturally, to what I, as the reviewer, personally consider to be of paramount importance to this whole issue of 'the problem of current channelling' – which is the application of the logic of William of Occam. Occam's Razor, as it is termed, states:

'It is vain to do with more  
what can be done with fewer'

which, in our context, can be interpreted as saying,

If we know *a priori* the conductive structure, and if models, be they numerical or laboratory, of the inductive effects of external sources on the structure can be constructed that adequately explain the observations, then there is no requirement for postulating current induced elsewhere flowing through the region of interest.

Obviously, the crux of this maxim is the prerequisite knowledge of the conductivity structure *per se*. Certainly all current perturbation effects due to land/sea coastlines can be analysed in this manner. However, intra-continental anomalies must be examined with great care, and accordingly this review is perhaps best served by considering in detail two regions of which there appears to be contention between those who believe that the observations are attributable purely to local induction, and those postulating the predominance of 'current channelling' effects. Mention will also be made of other areas of the world in which current channelling has been proposed to describe the observations. However, in order to limit the scope of this review to reasonable proportions, global studies will not be dealt with, little account will be paid to the coast effect, and the inducing field is assumed to be uniform. Also, the distortion of the electric field by near surface inhomogeneities will not be treated – although many workers in eastern Europe believe that such effects are the main cause of 'current channelling problems' (Vanyan, 1982, personal communication) – as this topic has already received attention in the excellent review by Berdichevsky and Dmitriev (1976). (For other, more recent, treatments of this subject see Larsen, 1977; Kemmerle, 1977; Lee, 1977; Hempfling and Schmucker, 1978).

Due to limitations of space the Brief Historical Review which formed the second chapter of the original manuscript, as distributed to the participants of the Sixth Workshop on Electromagnetic Induction in the Earth and Moon, has been replaced by Table I. The following section will consider some theoretical aspects of the 'problem',

TABLE I

## Brief Historical Review

Reference	
Price (1964)	comment that currents induced in the oceans could wend their way through the continents in an ohmic-like manner.
Whitham and Anderson (1965)	first work that postulated 'current channelling' in order to reconcile the MT and GDS observations at Alert, Canadian Arctic Archipelago.
Dyck and Garland (1969)	scale modelling experiments of the 'conductive channelling' effects on a tabular body representing the Alert anomaly.
Edwards <i>et al.</i> (1971)	classic work on GDS experiment in the British Isles and Eire. Postulated that in the period range 40–144 min. currents 'leaked' from the North Sea into the Irish Sea (and vice-versa) through southern Scotland. See Section 4.2.
Camfield <i>et al.</i> (1971)	identified a very strong narrow anomalous current system which could not be modelled by a suitable 2D numerical model. This North American Central Plains (NACP) anomaly is a linear feature striking north from the Black Hills of Dakota into northern Saskatchewan.
Porath <i>et al.</i> (1971)	
mid 1970's	a profusion of anomalies were attributed to the effects of current channelling rather than local induction. See Table II.
Babour and Mosnier (1977)	upon studying the properties of the anomalous horizontal magnetic field components by the differential geomagnetic sounding (DGS) technique, postulated that the anomalous field could undergo a separation of variables into spatial and temporal parts, which implied that channelled pseudo-direct currents were responsible and not locally induced currents.

and some concepts that may prove useful, in particular the aforementioned 'adjustment distance'. Also, a new type of 'induction arrow' is proposed in which the possible linear relationship between the anomalous vertically downward-directed magnetic field component and the two anomalous horizontal magnetic field components is derived by least-squares linear regression. Observations, numerical, laboratory, and field, are discussed in Section 3. However, a detailed examination of two 'problem' areas where contention appears to exist between the 'channellers' and the 'inductors' – the Rhinegraben and the Eskdalemuir anomaly – is reserved for Section 4. Finally, Section 5 attempts to draw conclusions and give suggestions for further work.

## 2. Some Theoretical Considerations and Various Useful Concepts

### 2.1. THE IMPORTANCE OF $\text{GRAD } \phi$

As shown in the elementary example in the introduction, the problem of current channelling is directly related to the buildup of charges on conductivity discontinuities, hence it may be expected intuitively that the important physical term is the gradient of the scalar electrostatic potential of those charges. Maxwell's equations in a whole space may be written in terms of a vector potential  $\mathbf{A}$ , and a scalar potential  $\phi$ , viz.,

$$\mathbf{E} = -\dot{\mathbf{A}} - \text{grad } \phi \quad (4)$$

$$\mathbf{B} = \text{curl } \mathbf{A} \quad (5)$$

$$\text{curl } \mathbf{B} = \mu \mathbf{J} \quad (6)$$

and, if we make the requirement that

$$\text{div } \phi + \rho/\epsilon = 0 \quad (7)$$

and

$$\text{div } \mathbf{A} = 0, \quad (8)$$

where  $\rho$  is the volume density of charges, we have physically identified the otherwise arbitrary scalar potential to describe explicitly the electrostatic potential. For a 'normal' (i.e., 1D) conductivity-depth distribution, there are no charges on any boundaries (a uniform source field has been assumed in accordance with the limitations of this review as stated in the introduction) and hence

$$\mathbf{E}_n = -\dot{\mathbf{A}}_n. \quad (9)$$

When there exists an anomalous zone of electrical conductivity, there is an anomalous electric field given by

$$\mathbf{E}_a = -\dot{\mathbf{A}}_a - \text{grad } \phi, \quad (10)$$

where the total vector potential is given by the sum of the normal vector potential and the anomalous vector potential,  $\mathbf{A} = \mathbf{A}_n + \mathbf{A}_a$ . As shown by Le Mouel and Menvielle (1982), in certain circumstances  $\dot{\mathbf{A}}_a \ll \text{grad } \phi$ , hence  $\dot{\mathbf{A}}_a$ , which expresses the self-induction of the perturbed currents, may be neglected when compared to the electrostatic field  $\mathbf{E}_e$ , given by  $\mathbf{E}_e = -\text{grad } \phi$ . Hence, the total electric field  $\mathbf{E}$ , given by

$$\mathbf{E} = \mathbf{E}_n + \mathbf{E}_a \quad (11)$$

can be approximated by

$$\mathbf{E} \simeq \mathbf{E}_n + \mathbf{E}_e \quad (12)$$

$$= -\dot{\mathbf{A}}_n + \text{grad } \phi. \quad (13)$$

The limiting assumption under which Equation (13) appears to hold is that the skin depth in the region in which the induction is most effective (generally taken as the ocean) is much greater than the characteristic scale length of the anomalous region,  $\delta \gg l$  – or, for flat thin structures of cross-section  $S$ , that  $\delta^2 \gg S$  (see Le Mouel and Menvielle for details). Thus, we note that currents are most strongly perturbed when the gradient of the electrostatic potential is of the same order of magnitude as the normal electric field.

## 2.2. ADJUSTMENT DISTANCE

The simple fault model in the Introduction illustrated well that there is an 'adjustment distance' within which great care must be exercised when interpreting the data. This 'adjustment distance' has been considered in detail in two recent publications dealing with  $B$ -polarisation induction in 2D bodies with thin sheet surfaces.

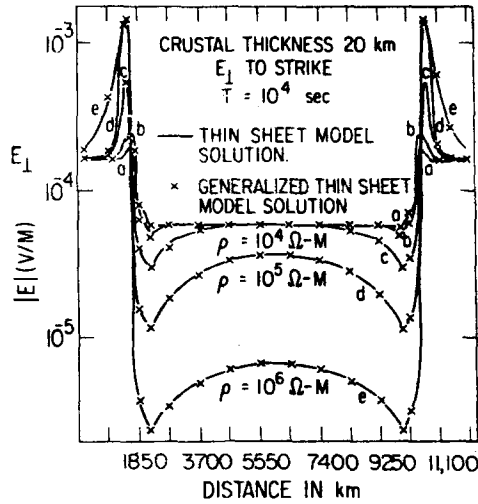

Fig. 3. Importance of crustal resistivity on ocean-continent edge effect for *B*-polarisation mode of induction [taken from Ranganayaki and Madden (1980)].

Ranganayamaki and Madden (1980) consider, what they term, a ‘generalised’ thin sheet analysis in which a surface double thin sheet approach is used to model the effects of a conducting zone overlying a resistive lower crust. The necessity of permitting poloidal current flow between the surface double sheet and the underlying half space for the *B*-polarisation mode of induction is clearly shown in Figure 1 of their work (reproduced here as Figure 3). Defining the integrated conductivity of the upper thin layer as  $S_1$ , and the integrated resistivity of the lower thin layer as  $R_2$  then obviously

$$S_1 R_2 > 1 \tag{14}$$

and the authors postulate that the scale length for the readjustment of the current flow to or from the upper mantle,  $\delta_a$ , is given by

$$\delta_a = (S_1 R_2)^{1/2} = (\sigma_1 h_1 \cdot h_2 / \sigma_2)^{1/2}, \tag{15}$$

where the upper and lower thin sheets have conductivities and thickness of  $(\sigma_1, h_1)$ , and  $(\sigma_2, h_2)$  respectively.

However, Dawson *et al.* (1982) obtained an exact analytical solution for this double layer problem in the *B*-polarisation mode, and showed that the exponential decay of the anomalous field on either side of a conductivity discontinuity in the top sheet (for this analysis the lower sheet must have the same characteristics on both sides of the discontinuity) is governed by the attenuation constants  $-\text{Im}(v_1^-)$  and  $-\text{Im}(v_2^-)$ , where

$$v_j^- = \left| \frac{\chi_j^-}{\sigma_0 h_2 / \sigma_2} - \frac{1}{\sigma^1 h_1 h_2 / \sigma_2} \right| \tag{16}$$

and



$$\chi_j^- = \frac{1}{2\sigma_0 h_2 / \sigma_2} - \left| \frac{1}{(2\sigma_0 h_2 / \sigma_2)^2} - \frac{1}{\sigma^1 h_1 h_2 / \sigma_2} + \frac{2i}{\sigma_0^2} \right|^{1/2}, \tag{17}$$

where  $\sigma^1$  is the appropriate conductivity in the upper thin sheet. As is apparent from inspection of Equation (16), (16) reduces to Equation (15) when  $\chi_j^- \sigma_2 / \sigma_0 h_2 \ll \sigma_2 / \sigma^1 h_1 h_2$ , i.e.,  $\chi_j^- \ll \sigma_0 / \sigma^1 h_1$ .

This above defined 'adjustment distance',  $\delta_a$ , is obviously correct only for a 2D model.

2.3. CURRENT CHANNELLING NUMBER

In a recent publication, Edwards and Nabighian (1981) have introduced the concept of a 'current channelling number' to describe the response of a truly 2D body to excitation

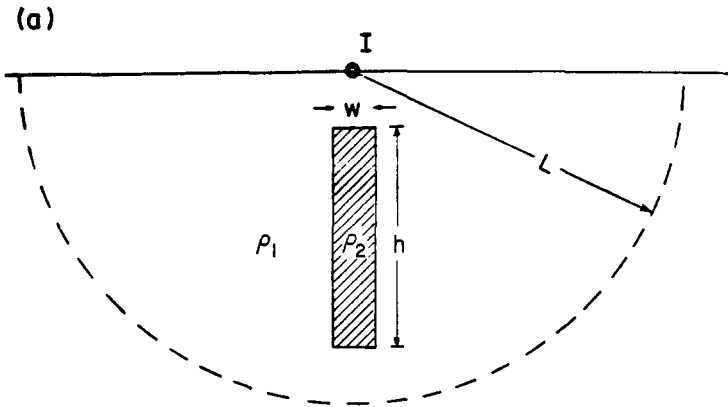

L - PROFILE OFFSET DISTANCE

(b)

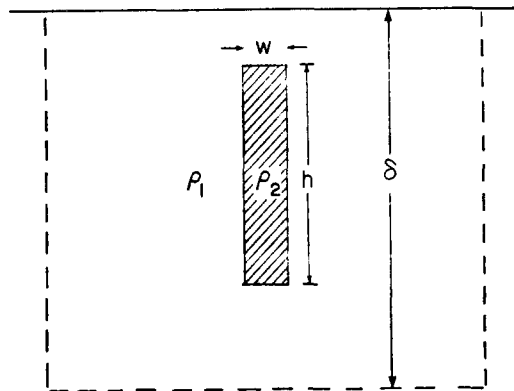

delta - SKIN DEPTH IN HOST MEDIUM (rho\_1)

Fig. 4a. The effective area of influence of a dyke for a controlled source survey; b) The effective area of influence of a dyke for a natural source survey.

by a controlled source in the equivalent of the 'E-polarisation' mode. Consider a conducting dyke, of conductivity  $\sigma_2$ , width  $w$ , thickness  $h$ , in an otherwise uniform host medium of conductivity  $\sigma_1$  (see Figure 4a) excited by a current source on the surface of the host medium close to the dyke. At distance  $L$  down strike of the current source, the ratio of the current flowing in the dyke to the total available current is clearly, by Ohm's Law, represented by the areal conductivity of the dyke to the effective areal conductivity of the host medium plus dyke, i.e.,

$$\frac{\text{current in dyke}}{\text{total available current}} = \frac{wh\sigma_2}{\sigma_1\pi L^2/2 + wh\sigma_2} \quad (18)$$

for  $wh \ll L^2$ . Defining a dimensionless response number,  $\alpha$ , such that this ratio is equal to  $\alpha/(1 + \alpha)$ , then obviously

$$\alpha = \frac{2wh\sigma_2}{\sigma_1\pi L^2} \quad (19)$$

and the response number can be recognized as a measure of the current 'channelled' in the dyke. This response number,  $\alpha$ , is bounded to the range  $0 \leq \alpha \leq 1$ . For  $\alpha$  small, less than say 0.1, due to either a small cross-sectional area of the dyke compared to  $L$  ( $wh/L$  small), or small conductivity contrast ( $\sigma_2/\sigma_1$  small), then there is little extra current flowing in the dyke than in an equal area of the host and there will be no appreciable magnetometric resistivity anomaly (Edwards 1974). For larger  $\alpha$ , greater than 0.9 say, due to either  $wh/L$  large or  $\sigma_2/\sigma_1$  large, then the vast majority of the current will flow preferentially in the dyke.

We may take this useful-concept in applied em theory and consider an equivalent for natural source techniques. The effective area of induction, at a specific frequency, is obviously related to the skin depth in the host,  $\delta_h$  (Figure 4b). The zone of influence of a better conducting body, i.e., the cross-sectional area within which the presence of a body causes a perturbation in the lines of current flow, will be, to a first approximation, equal to a square with sides  $\delta_h$  long, and hence the equivalent 'current channelling number' for the 2D dyke would be

$$\alpha_2 = \frac{wh}{\delta_h^2} \cdot \left(\frac{\sigma_2}{\sigma_1}\right). \quad (20)$$

However, we are not concerned here with 2D problems, as there is no 'current channelling' in a 2D body excited by a uniform source (only by a non-uniform source), but with the more general 3D structures. For a dyke of limited extent, of length  $l$ , then this 'current channelling number' will be given by the ratio of the volumetric conductivity of the dyke to the effective volumetric conductivity of the host, i.e.,

$$\alpha_3 = \frac{whl}{\sigma_h^3} \cdot \left(\frac{\sigma_2}{\sigma_1}\right). \quad (21)$$

Obviously,  $\alpha_3 = \alpha_2 \cdot (l/\delta_h)$ , which indicates that the '3D-ness' of a structure, or how much data from a profile over the structure differ from a 2D response, is dependent on

the dimensionless ratio  $l/\delta_h$ . If the body and the frequency of interest are such that this ratio  $l/\delta_h$  is far greater than 1, then a 2D interpretation of the data should give approximately the correct conductivity structure (provided that the profile was conducted away from the 'faces' of the body). However, if the body is too short, i.e.  $l$  small, or the frequency is too low, i.e.  $\delta$  large, then this ratio will be smaller than 1 and a 2D interpretation of the responses observed will not be valid.

2.4. CORRELATION OF THE ANOMALOUS CURRENT FLOW

One of the main contentions of many of those believing in 'current channelling' is that the anomalous horizontal fields  $h_{io}(t)$ ,  $d_{io}(t)$  are linearly related to each other (Babour *et al.*, 1976; Woods and Lilley, 1980) by  $h_{io}(t) = k_i d_{io}(t)$ . In the frequency domain, as  $k_i$  is considered to be a real, frequency-independent constant, then

$$H_{io}(\omega) = K_i \cdot D_{io}(\omega) \tag{22}$$

and obviously the polarisation parameters estimated from the anomalous horizontal field components (by the technique given in Fowler *et al.*, 1967) should reveal a linearly polarised field of frequency independent azimuth given by

$$\theta_i = \frac{1}{2} \tan^{-1} \left[ \frac{2K_i}{K_i^2 - 1} \right] \tag{23}$$

clockwise round from north.

If the base station, station 'o', is on a truly 1D earth structure, and if the source field is sufficiently uniform that (a) a negligible  $H_z$  field is observed at the base station, and (b) that the inducing field at the remote station 'i' has exactly the same characteristics as at 'o', then we may define the truly anomalous fields observed at 'i' as

$$H_a(\omega) = H_{io}(\omega) = H_i(\omega) - H_o(\omega) \tag{24a}$$

$$D_a(\omega) = D_{io}(\omega) = D_i(\omega) - D_o(\omega) \tag{24b}$$

and

$$Z_a(\omega) = Z_{io}(\omega) = Z_i(\omega) \tag{24c}$$

(equivalent equations exist in the time domain), where obviously  $Z_a$  is the total vertical field observed at 'i'. Schmucker (1970) has already provided a tensor relationship between the normal (as observed at 'o') and the anomalous fields, viz.

$$\begin{bmatrix} H_a \\ D_a \\ Z_a \end{bmatrix} = \begin{bmatrix} h_H & d_D \\ d_H & d_D \\ z_H & z_D \end{bmatrix} \begin{bmatrix} H_o \\ D_o \end{bmatrix} \tag{25}$$

and has defined induction vectors and perturbation vectors to describe both the direction in which induction is most effective, and the direction of flow of the anomalous internal fields. Defining  $[i, j]$  to be the Cartesian unit vectors pointing toward north and east respectively, induction vectors  $v_r$  and  $v_i$ , at frequency  $\omega$ , are defined by

$$\mathbf{v}_r(\omega) = -\operatorname{Re}[Z_H(\omega)] \cdot \mathbf{i} - \operatorname{Re}[Z_D(\omega)] \cdot \mathbf{j} \quad (26a)$$

$$\mathbf{v}_i(\omega) = +\operatorname{Im}[Z_H(\omega)] \cdot \mathbf{i} + \operatorname{Im}[Z_D(\omega)] \cdot \mathbf{j} \quad (26b)$$

[Note: for  $\mathbf{v}_i(\omega)$  there appears to be profuse confusion as to whether it should be reversed or not. In a very lucid article, Lilley and Arora (1982) discuss this point in detail and show that the implicit definition of time dependence, either  $\exp(-i\omega t)$  or  $\exp(i\omega t)$ , dictates what course of action must be taken].

The complex perturbation vectors,  $\mathbf{p}$  and  $\mathbf{q}$ , are defined by

$$\mathbf{p} = h_H \cdot \mathbf{i} + d_H \cdot \mathbf{j} \quad (27a)$$

$$\mathbf{q} = h_D \cdot \mathbf{i} + d_D \cdot \mathbf{j} \quad (27b)$$

and, on rotating them counterclockwise by  $90^\circ$ , they indicate the directions and strengths of the anomalous internal current fields which are superimposed upon the westward ( $\mathbf{p}$ ), respectively northward ( $\mathbf{q}$ ), flow of unperturbed normal currents. These perturbation vectors have been little employed within the induction community, in particular amongst those advocating 'current channelling', although they might prove highly useful for delineating the flow of anomalous currents for a particular source configuration (analogous to the Hypothetical Event Analysis of Bailey *et al.*, 1974).

Babour *et al.* (1976) noted that the vertical magnetic component at an anomalous station was very similar to the horizontal difference fields. Such an effect would also be true of induction in an elongated body. Hence, this observation leads quite naturally to the suggestion that  $Z_a(\omega)$  and  $[H_a(\omega), D_a(\omega)]$  may be related by transfer functions  $[A'(\omega), B'(\omega)]$  defined such that the error  $\varepsilon$  in the equation

$$Z_a(\omega) = A'(\omega) \cdot H_a(\omega) + B'(\omega) \cdot D_a(\omega) + \varepsilon \quad (28)$$

is minimised in a least-squares sense. From  $[A'(\omega), B'(\omega)]$ , we can define 'anomalous induction vectors',  $\mathbf{a}_r$  and  $\mathbf{a}_i$ , such that

$$\mathbf{a}_r = -\operatorname{Re}[A'] \cdot \mathbf{i} - \operatorname{Re}[B'] \cdot \mathbf{j} \quad (29a)$$

$$\mathbf{a}_i = -\operatorname{Im}[A'] \cdot \mathbf{i} - \operatorname{Im}[B'] \cdot \mathbf{j} \quad (29b)$$

and obviously, in the near field of an equivalent line current,  $\mathbf{a}_r \gg \mathbf{a}_i$ , and both point toward concentrations of current in conductivity inhomogeneities. However, there exists a distance along the profile perpendicular to the flow of anomalous current at which  $\operatorname{Re}(Z_a) = 0$ , i.e.  $\mathbf{a}_r = 0$ , beyond which  $\mathbf{a}_i$  is still pointing towards the anomalous current flow but  $\mathbf{a}_r$  is pointing away from it. Also, these vectors indicate anomalous current flow, which may be either greater than normal (in a good-conducting body), or less than normal (in a more poorly-conducting body than the host medium), and hence the induction vectors as more conventionally defined must be taken into consideration when interpreting these anomalous induction vectors.

To illustrate an example of the advantages of the ratio  $Z/H_a$ , rather than the more common one of  $Z/H$ , consider an anomalous region consisting of a half cylinder placed on top of the interface between two layers (Figure 5b). Summers (1982) has calculated

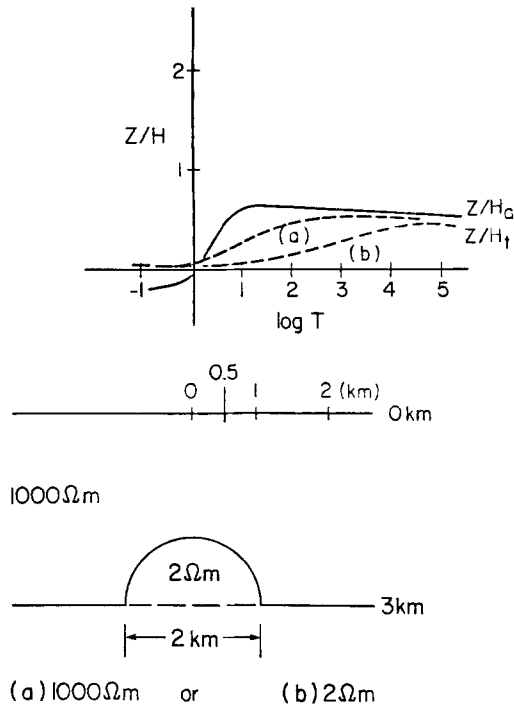

Fig. 5. The comparison of the  $Z/H$  ratios (dashed lines) and  $Z/H_a$  ratios (full line) for the models illustrated of (a) an embedded half-cylinder, and (b) an undulation in a good conducting layer.

the ratios  $Z/H$  and  $Z/H_a$  for this model for two cases; (a) when the lower layer takes the same resistivity as the upper one, i.e.,  $1000\Omega\text{m}$ , so that the anomaly is embedded in a half space, and (b) when the lower layer takes the same value of resistivity as the half cylinder itself, i.e.,  $2\Omega\text{m}$ , such that the anomaly is an undulation in the transition zone to a conducting layer. Summers shows that over the whole range of periods from  $0.1$  to  $10^4$  s, the ratio  $Z/H_a$  (i.e., the 'anomalous' induction vector) is almost exactly the same for both case (a) and case (b), whereas the ratio  $Z/H$  (i.e., the 'conventional' induction vector) is different for both cases. Thus, the 'anomalous' induction vector appears to be more independent of the 'normal', or 1D, structure, and more dependent on the anomaly itself, than does the conventional induction vector. Also, the anomalous induction vector is of much larger amplitude than its conventional counterpart, and hence it will be more sensitive to variations in any 2D or 3D model. One other important point to notice about Figure 5a is that the vertical-to-anomalous-horizontal field ratio is virtually independent of frequency at periods longer than 10 s, whilst the vertical-to-total-horizontal field ratio is very frequency dependent.

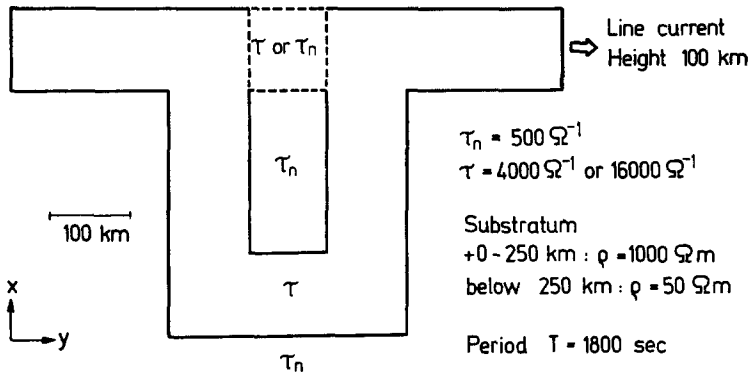

Fig. 6. The thin sheet model considered by Weidelt [taken from Weidelt (1977)].

### 3. Observations

#### 3.1. NUMERICAL

The numerical observations of the effects of current perturbations due to 3D bodies are growing as workers consider models of greater and greater complexity. Fortunately, the subject of electromagnetic induction in 3D structures has already been reviewed at an earlier workshop (Hewson-Browne and Kendal, 1977), and there is a complete session on it at this one (Hohmann, 1983). Hence, I will merely pick out some of the interesting results of numerical modelling that shed light on the problem of current channelling.

The possible current perturbation effects due to 3D structures have been studied using a thin sheet approximation to model the lateral variation of conductivity in the surface layers. Haak (1978), and more recently Hermance (1982), have considered the telluric distortion effect in a thin sheet of laterally varying conductance,  $\tau(x, y)$ , overlying a 1D layered half space, by assuming that the inductive coupling between currents flowing in the sheet is negligible, and that current does not flow between the thin sheet and the underlying medium, i.e., the sheet is electrically not in contact with the underlying layer. This neglect of poloidal current flow reduces the problem to one of solving for a 2D potential function  $U(x, y)$  that satisfies Laplace's equation. [This form of treatment was termed 'unimodal induction' by Vasseur and Weidelt (1977).] However, Vasseur and Weidelt showed that at very long periods the poloidal mode current systems predominate – which are exactly the current systems ignored. Accordingly, the results of analyses of the form described by Haak and Hermance must be treated with some caution.

Weidelt (1977) appears to have been the first to use numerical modelling to study a current perturbation phenomenon *per se*. In an investigation of the model illustrated in Figure 6, by adopting a thin sheet approximation which permitted poloidal current flow, Weidelt showed that for a 'central' profile, in the 'closed' mode, i.e., the gap had a conductance of  $\tau$ , and for  $\tau = 4000$  S, there is no leakage of current. For the 'open' mode, i.e., the gap had a conductance of  $\tau_n$ , the total equivalent current (Figure 7a) does

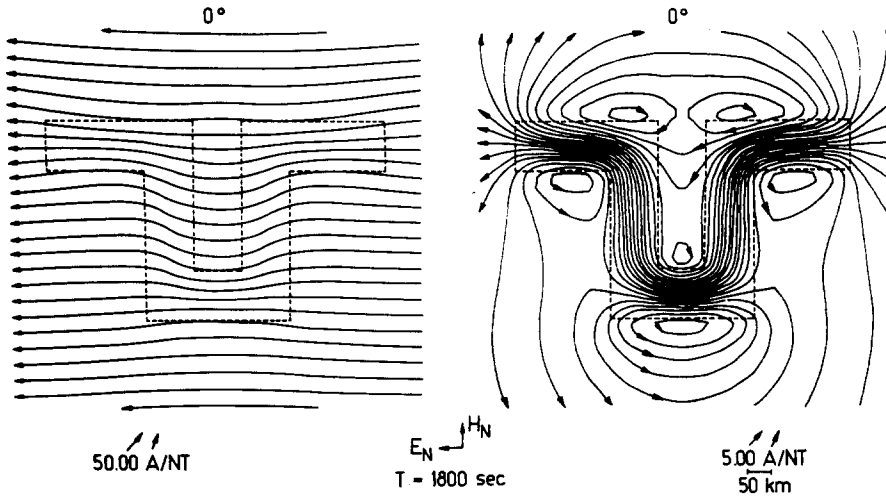

Fig. 7. The open mode equivalent current system (left) and the anomalous currents (right) [taken from Weidelt (1977)].

indicate that a minor effect would be exhibited, as shown by the anomalous equivalent current flow (Figure 7b). For  $\tau = 1600$  S, equivalent to a deep ocean, then these effects are more pronounced. However, Weidelt concluded that the conditions under which a current channelling effect could be achieved were 'rather extreme and certainly not satisfied in nature'.

Vasseur and Weidelt (1977) attempted to model the effects of the north Pyrenean anomaly using the same approach of 'bimodal induction', i.e., of permitting both poloidal and toroidal current modes. They found that as the frequency tended to zero, i.e., at very long periods, then the poloidal mode predominated such that the anomalous electric fields resulted from a 'DC-like' distortion of current lines, and induction effects were not important. However, the magnetic field associated with the negligible anomalous toroidal electric field was certainly not insignificant. Also, in the low frequency limit there was almost no phase shift over the anomalous domain, and the anomalous electric and magnetic fields had the same phase as the normal electric field. These two effects certainly described the field observations that the space and time variables appeared to be decouplable.

A more general approach to 3D induction in a non-uniform thin sheet is afforded by Dawson and Weaver's (1979) treatment, in which the model may have either an  $E$ -polarisation or  $B$ -polarisation configuration at 'infinity'. The method has so far been applied to model the Vancouver Island region (Dawson and Weaver, 1979), northern Scotland (Weaver, 1982) and northern Scandinavia (Jones and Weaver, 1981). Also, McKirdy (personal communication 1982) has considered the case of a thin channel connecting two large 'seas' (Figure 8). The main interest in this work was to discover under what circumstances a traverse from the centre of one 'continent' to the other could be validly interpreted by a 2D model. McKirdy compared the various field

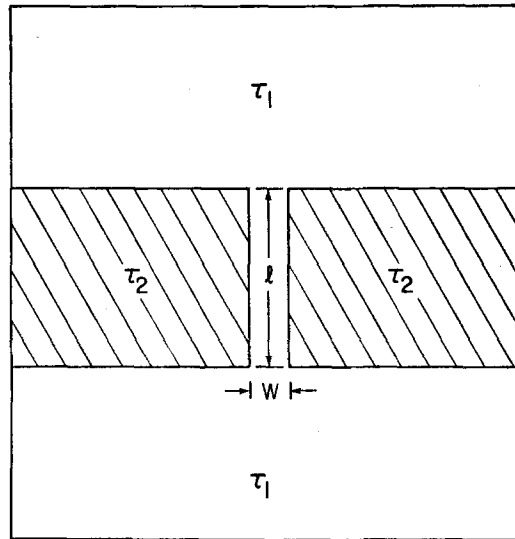

Fig. 8. The model considered by McKirdy of a thin strait connecting two seas between two continents.

components for differing 'aspect ratios', where the aspect ratio  $\alpha$  is given by the length of the channel,  $l$ , divided by the width,  $w$ , i.e.,  $\alpha = l/w$ , for both the '*E*-polarisation' mode, and the '*B*-polarisation' mode. (These two terms are used loosely here to describe whether the inducing magnetic field was perpendicular ('*E*-polarisation') or parallel ('*B*-polarisation') to the strike of the interconnecting channel.) For a conductance ratio of 30, i.e.,  $\tau_2/\tau_1 = 30$ , and a channel width of  $1/3$  of the skin depth in the underlying half space, the *E*-polarisation results for all components were equal to those for a 2D model along the aforementioned profile for aspect ratios greater than about six. The electric component  $E_x$  was the most sensitive to variations in  $\alpha$ . The magnetic field components [ $B_y, B_z$ ] were far less sensitive, and indeed  $B_y$  was indistinguishable from the 2D solution for  $\alpha \gtrsim 4$  or so, whilst  $B_z$  did not differ significantly from the 2D solution for  $\alpha = 2$  or greater. Hence, the  $B_z/B_y$  ratios, or 'conventional' induction vectors, will lead to the correct conductivity distribution below the profile for  $\alpha = 4$  or greater for this particular model. For the *B*-polarisation mode the situation was very different. As  $\alpha$  was increased, the components [ $B_y, B_x$ ] tended towards the 2D solutions, but even for  $\alpha = 12$  there was still a large discrepancy between the 2D and the 3D solutions.

The majority of 3D models considered by workers who have developed full 3D forward modelling programmes are of a conducting body in an otherwise uniform more resistive half space. Weidelt (1975) considered an exposed conducting body, and was able to show that, for a central profile over the body in the '*E*-polarisation' mode, the 2D description was adequate for  $\alpha > 3$  (Figure 9). It should be noted that the conductivity contrast was small (10 : 1), and that the skin depth in the host medium at the period of interest was approximately 20 km, so that  $l/\delta_h$ , the ratio of the 3D/2D current channelling numbers, was greater than 1 for  $l/w > 2$ . Hence, the effects of the



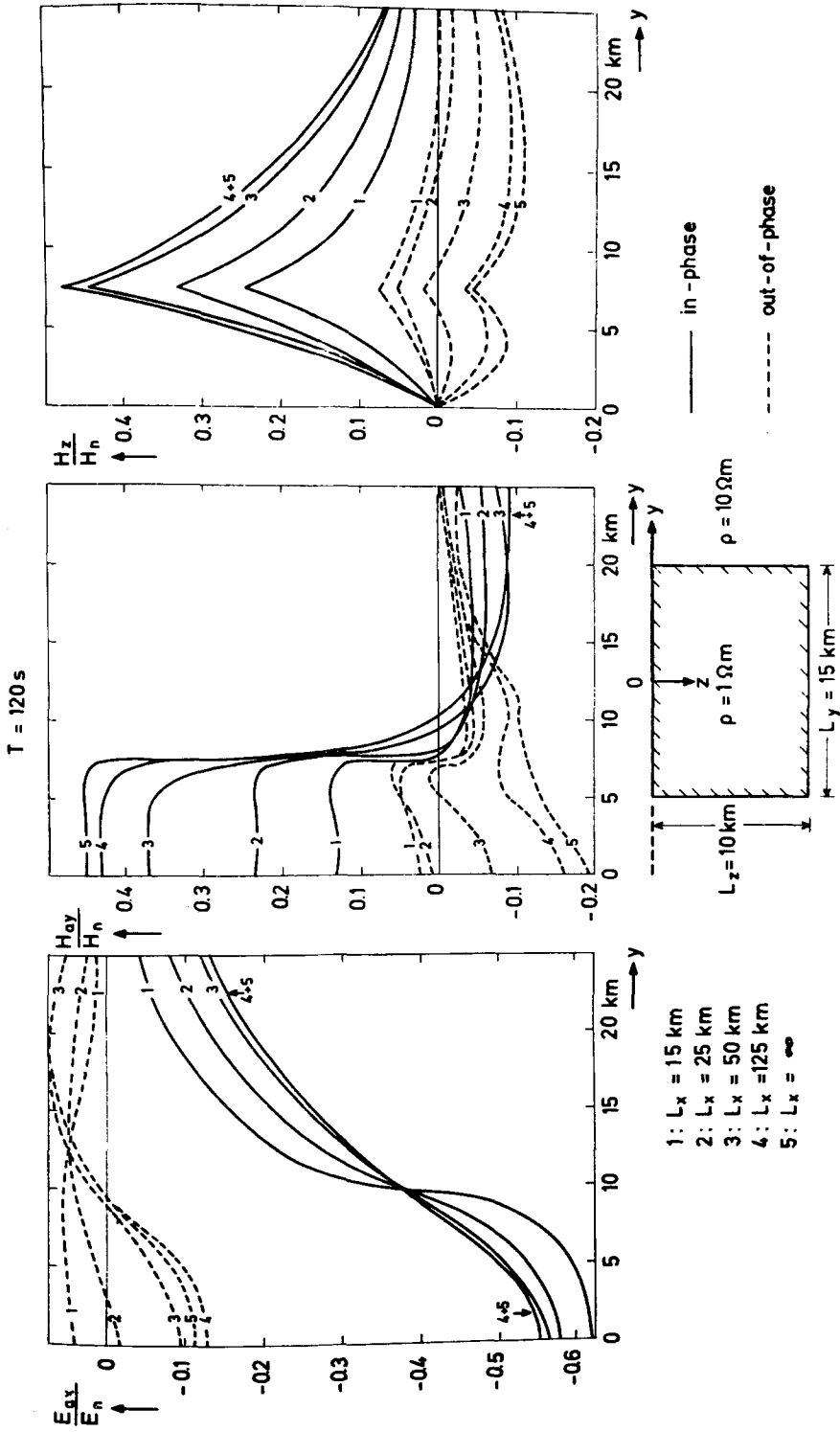
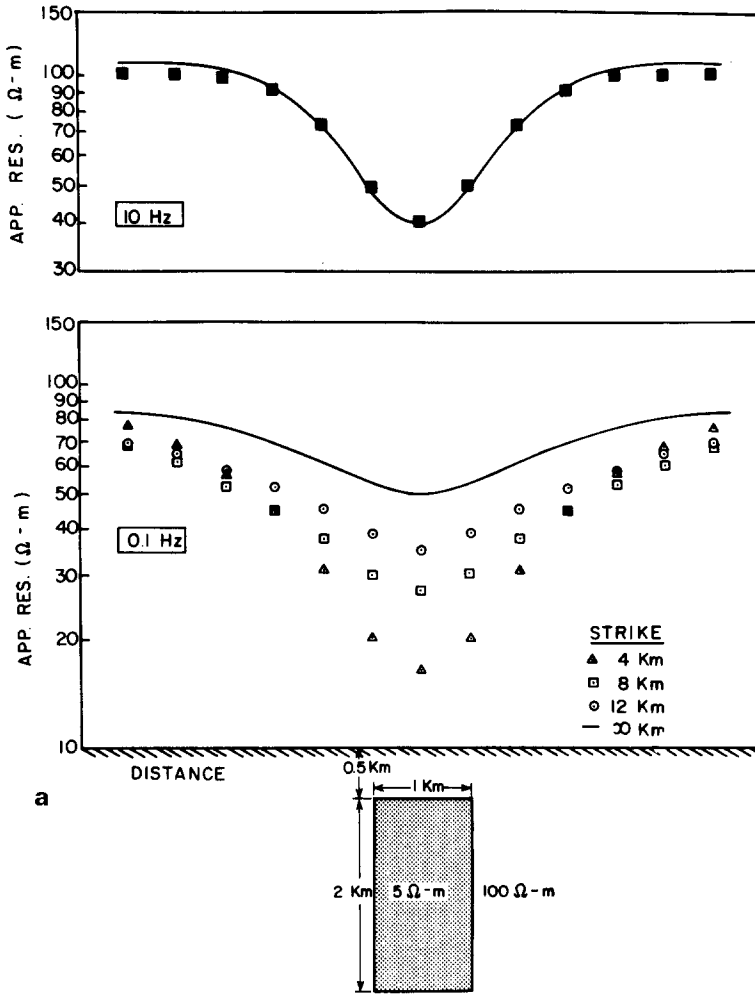

Fig. 9. The variation of the normalised electromagnetic fields for varying aspect ratios for the 3D body illustrated [taken from Weidelt (1975)].



charges built up on the ‘faces’ of the 3D body are not seen some 2 skin depths away, equivalent to  $L_x > 100$  km (i.e., curve 4 on Figure 9).

Ting and Hohmann (1981) considered a conducting body, of conductivity contrast 20:1, buried beneath the surface. As shown in Figure 10b, for their body the  $B$ -polarisation mode can be approximated as 2D for  $l/w > 4$ . However, in the  $E$ -polarisation mode, the length-to-breadth ratio at which a 2D solution is satisfactory was frequency dependent (see Figure 10a). For a frequency of 10 Hz,  $\delta_h = 1.5$  km, hence  $l/\delta_h > 1$  for even the shortest strike length considered of 4 km. Thus, it is not surprising that a 2D solution was sufficient. For a frequency of 0.1 Hz (10 s) however,  $\delta_h = 15$  km and  $l/\delta_h$  never reached 1 even for a strike of 12 km, although a 2D solution for a strike length of 12 km was fairly close to the correct 3D apparent resistivity.

These two examples illustrate well that rule-of-thumb type arguments of the form ‘as long as the length-to-breadth ratio is greater than  $n$  (a seemingly arbitrary figure at

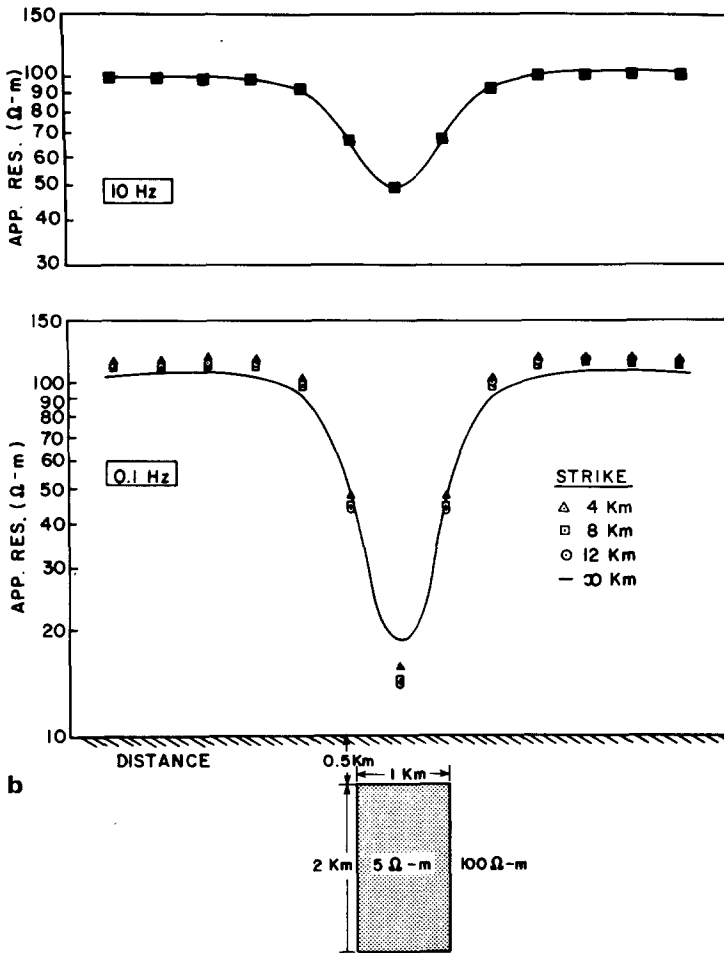

Fig. 10. The variation of the MT apparent resistivity for varying aspect ratio for the body illustrated at two different frequencies in the (a) 'E-polarisation' and the (b) 'B-polarisation' mode of induction [taken from Ting and Hohmann (1979)].

present believed to be about 3) a 2D solution is sufficient' carries absolutely no weight and can indeed be highly misleading (see, for example, Figure 10a for a strike of 4 km). The physical character of the induction processes indicate that a meaningful parameter to consider is the ratio of the strike length to skin depth in the host medium,  $l/\delta_h$ , when statements regarding the validity of approximating a 3D body by a 2D solution are being made. For an embedded body, it appears that the 'B-polarisation' results can be satisfactorily modelled by a 2D approach for fairly small values of  $l/\delta_h$ , i.e., of the order of tenths of unity. For the 'E-polarisation' mode however, it is clear that this ratio must be at least unity for an adequate representation by a 2D model, as a rough guide the profile should be at least one skin depth (in the host medium) away from either of the two 'faces'. Hence, for short 3D bodies, preferential interpretation of the B-polarisation

TABLE II

'Crustal' conductivity anomalies attributed to current channelling protagonists and antagonists

Alert, Canada		
pro.	Whitham and Andersen (1965) Dyck and Garland (1969) Niblett <i>et al.</i> (1974) Drury and Niblett (1980)	ant. Porath and Dziewonski (1971) Praus <i>et al.</i> (1971)
Mould Bay, Canada		
pro.	DeLaurier <i>et al.</i> (1974) DeLaurier <i>et al.</i> (1980)	
Yukon, Canada		
pro.	DeLaurier <i>et al.</i> (1981)	
Greenland		
pro.	Wilhjelm and Friis-Christensen (1973)	
Morocco		
pro.	Le Borgne and Le Mouel (1975) Menvielle and Rossignol (1982)	
Australia		
pro.	Woods and Lilley (1980)	
Eskdalemuir anomaly, Scotland		
pro.	Edwards <i>et al.</i> (1971) Bailey and Edwards (1976) Green (1975) Dosso <i>et al.</i> (1980) Nienaber <i>et al.</i> (1981) Ingham and Hutton (1982)	ant. Jones and Hutton (1979a, b) Ingham and Hutton (1982)
Great Glen, Scotland		
pro.	Kirkwood <i>et al.</i> (1981)	
Sierra Nevada, U.S.A.		
pro.	Lienert (1979)	
Rhinegraben		
pro.	Babour and Mosnier (1979, 1980) Albouy and Fabriol (1981)	ant. Dupis and Thera (1982) Summers (1981, 1982) Hebert (1983)
NACP, U.S.A.		
pro.	Porath <i>et al.</i> (1971) Gough (1973) Alabi <i>et al.</i> (1975)	ant. Handa and Camfield (1982)
Northern Pyrenees		
pro.	Babour <i>et al.</i> (1976) Vasseur <i>et al.</i> (1977) Vasseur and Weidelt (1977)	
The Palk Strait, Sri Lanka/India		
pro.	Nityananda <i>et al.</i> (1977) Singh <i>et al.</i> (1977) Rajaram <i>et al.</i> (1979) Thakur <i>et al.</i> (1981)	
Northwestern U.S.A.		
pro.	Booker and Hensel (1981)	
British Columbia, Canada		
pro.	Dragert (1973)	

mode MT results and of the  $E$ -polarisation  $B_z/B_y$  ratios, in terms of an acceptable 2D model, should be undertaken.

In the case of a conducting body which connects two vast regions of high conductivity, as, for example, the thin channel between the two seas considered by McKirdy (Figure 8), it is clear that whilst approximately the same statements appear to hold for the  $E$ -polarisation mode (a 2D model was valid for  $l/\delta_h > 3$ ), in the  $B$ -polarisation mode then  $l/\delta_h \gg 1$  must be true before a 2D approximation is valid.

### 3.2. LABORATORY

By far the vast majority of the published literature on laboratory analogue measurements were undertaken to delineate features of varying ocean-continent boundaries by

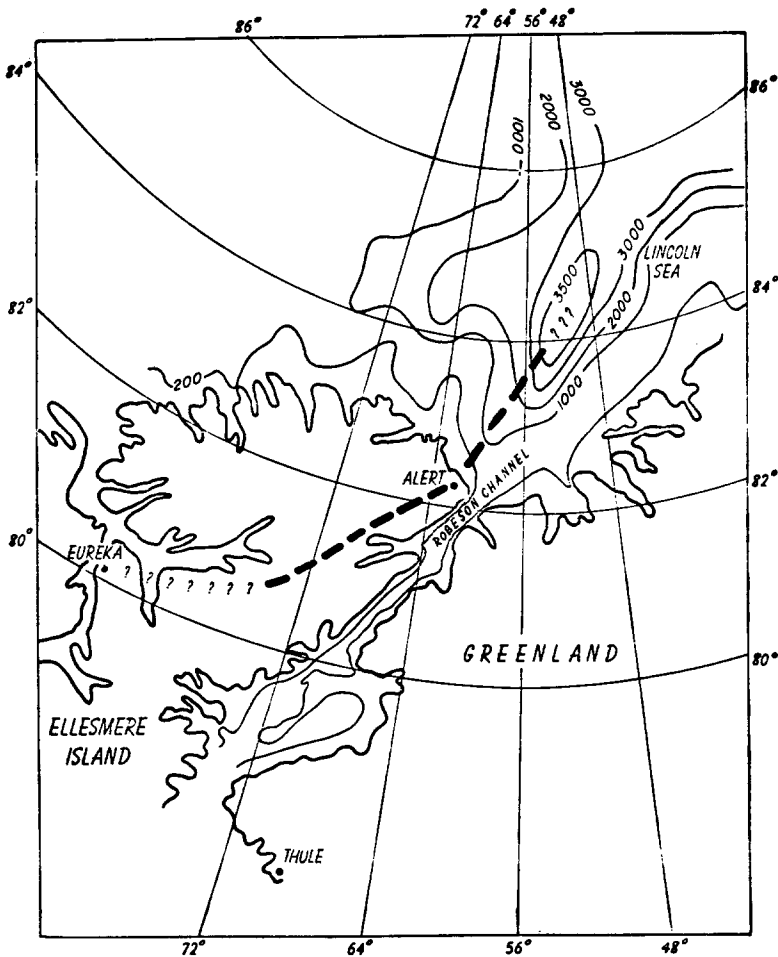

Fig. 11. The bathymetry around northern Ellesmere Island and Greenland with the postulated position of the Alert anomaly.

Dosso and his co-workers. These studies provide an excellent reference for some field data to be compared with – if the model can adequately describe the observations then there is no requirement to postulate the existence of either crustal conductivity anomalies or ‘current channelling’. Dyck and Garland (1969) modelled explicitly the effects of a channelled current in the Alert anomaly, and Dobrovolskaya and Kovtun (1978) compared the 2D results of an axially symmetric upwelling in a perfectly insulating layer to the 3D ones of a short rampart with varying length-to-width ratios. The latter authors concluded that for a length-to-width ratio  $> 5$ , a 2D approximation is valid in the  $B$ -polarisation mode.

### 3.3. FIELD

The question now arises as to whether any of the field observations can be attributed to the effects of a channelled current in an elongated conductor, or whether a simpler explanation in terms of local induction exists. Also, the existence of certain of the ‘crustal’ anomalies quoted in Table II is suspect due to the presence of irregular coastlines and nearby islands – this is true of Alert, Mould Bay, Greenland, Morocco, Brittany, and the Palk Strait. For all measurements close to coastlines, the observations can be very dependent on the highly local character of the shape of the coastline, as was shown in the analogue modelling study of capes and bays by Chan *et al.* (1981). Also, the presence of an island off the coast can lead to apparently anomalously large magnetic fields being observed (see, for example, Nienaber *et al.*, 1976, 1977; Ramaswamy *et al.*, 1977).

For the Alert anomaly, Porath and Dziewonski (1971) conjectured that current flow in the Robeson Channel (see Figure 11) could account for many of the observations. This theory was strongly opposed by Praus *et al.* (1971) and Niblett *et al.* (1974). However, it is perhaps not without significance that the proposed extension of the Alert anomaly to the northeast, as mapped by Niblett *et al.* (1974), follows almost exactly a line normal to the contours of the bathymetry into the deepest part of the Lincoln Sea (see Figure 11) – which could account for the effects persisting out into the Lincoln Sea far beyond the Robeson Channel entrance. Also, the ‘current channelling’ hypothesis for the anomaly was challenged by Praus *et al.* (1971), who noted that the frequency dependence of their GDS and MT observations was not fully compatible with purely conductive current flow.

The Palk Strait anomaly, as postulated by Thakur *et al.* (1981), can probably be explained by considering reference to the analogue modelling work quoted above. There may be no need to demand a conducting zone beneath the Strait.

Considering intra-continental anomalies, certainly the North American Central Plains (NACP) anomaly is by far the most dominant. However, taking into account the discussion in Section 2, it is rather surprising that Porath *et al.* (1971) were unable to discover a satisfactory 2D model – at the shorter periods studied, the length to skin depth in the host ratio,  $l/\delta_h$ , greatly exceeds unity. Handa and Camfield (1982) have made MT and GDS observations along a profile in northern Saskatchewan, to delineate the northern extension of the NACP anomaly as mapped by Alabi *et al.*

(1975). They were able to describe their responses by choice of a suitable 2D model with a conducting block at lower crustal/upper mantle depths.

A large proportion of the anomalies attributed to 'current channelling' effects rather than local induction are believed so because of the conclusions of Differential Geomagnetic Sounding (DGS) experiments carried out over them. Hence, we should consider in detail the tenets of the belief that the difference fields are linearly related by a frequency independent constant, with the associated 'simplest' interpretation that a separation of spatial and temporal variables is valid. Such a separation was shown by Le Mouel and Menvielle (1982) to be possible if the anomalous fields result from electrostatic currents only, and if the 'normal' electric field is separable into temporal and spatial parts. However, the restrictions under which the anomalous electric field is purely electrostatic require periods sufficiently long that  $\delta \gg l$ , i.e., the skin depth in which the most effective induction is taking place (not the skin depth of the 'host' in this case), usually assumed to be the oceans, is far greater than the scale length of the anomaly. This is certainly not true at periods shorter than about 1 hr, and accordingly we must seriously question whether the difference fields are so simply related at short periods as they appear to be in Babour, Mosnier and co-authors' works.

Beamish (1982) has undertaken a detailed examination of the validity of the statements of Babour and co-workers, by analysing his data in both the time and frequency domains. In all the DGS experiments reported in the literature, there appears to be a linear relationship between the difference fields measured at two sites, 'i' and 'j', and the reference site 'o', such that

$$h_{io}(t) = \lambda_{ij} \cdot h_{jo}(t) \quad (30a)$$

and

$$d_{io}(t) = \mu_{ij} \cdot d_{jo}(t) \quad (30b)$$

also

$$h_{io}(t) = k_i \cdot d_{io}(t) \quad (30c)$$

where

$$h_{io}(t) = h_i(t) - h_o(t) \quad (31a)$$

and

$$d_{io}(t) = d_i(t) - d_o(t) \quad (31b)$$

[it is obvious that the constants  $\lambda_{ij}$ ,  $\mu_{ij}$ ,  $k_i$ , and  $k_j$  must be inter-related such that  $k_i = k_j \mu_{ji} \lambda_{ij}$  is true]. Beamish (1982) analysed synchronous data from 3 closely spaced stations (largest inter-station separation was 32 km) straddling the Scotland/England border by both a sonogram technique (a bank of 9 narrow band-pass filters with differing centre period) in the time domain, and standard statistical frequency analysis techniques in the frequency domain. The time domain hodogram plots of the difference fields,  $h_{io}(t)$  against  $d_{io}(t)$ , are compared with those of the total fields,  $h_i(t)$  against  $d_i(t)$ , in Figure 12, for 5 of the 9 frequency bands considered (the centre periods of the bands

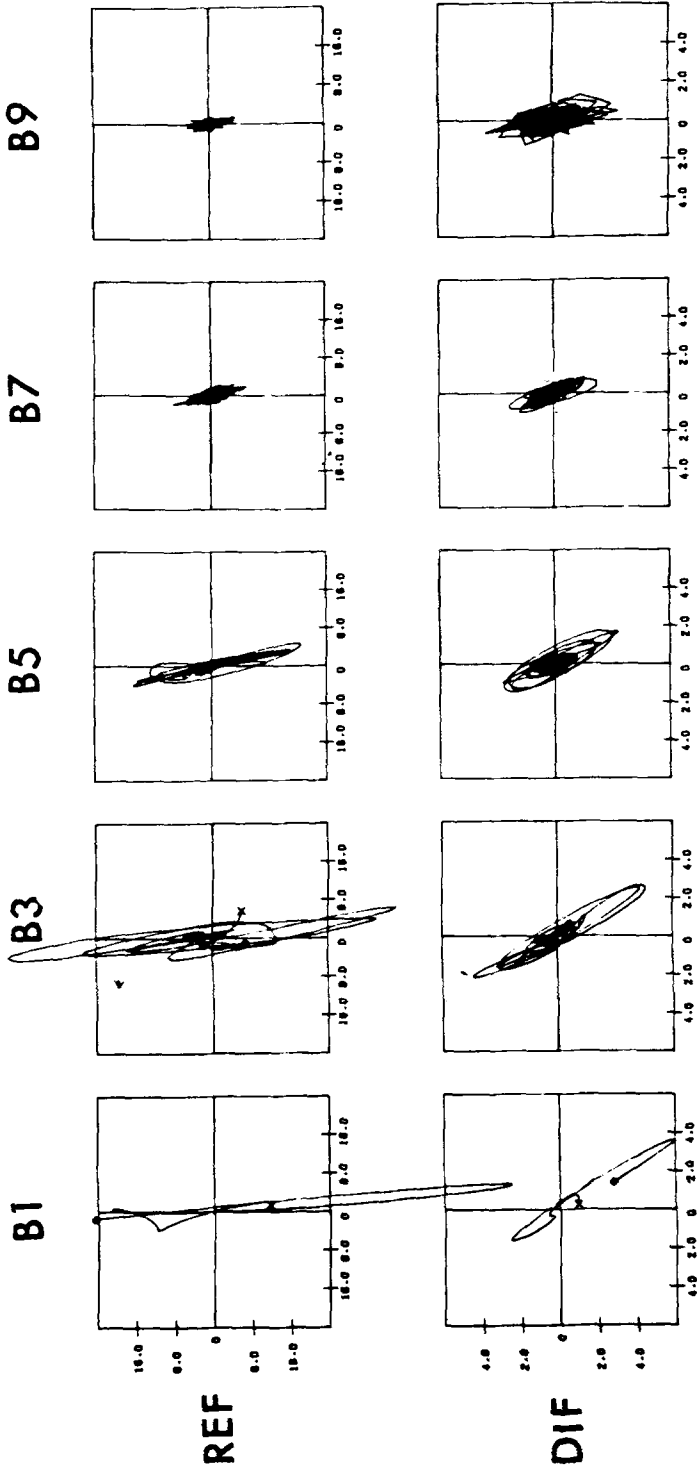

Fig. 12. The time domain hodograms of the total horizontal magnetic field (upper) and the difference horizontal magnetic field (lower) in 5 of the 9 period bands considered by Beamish - for centre periods see Figures 14 and 15.



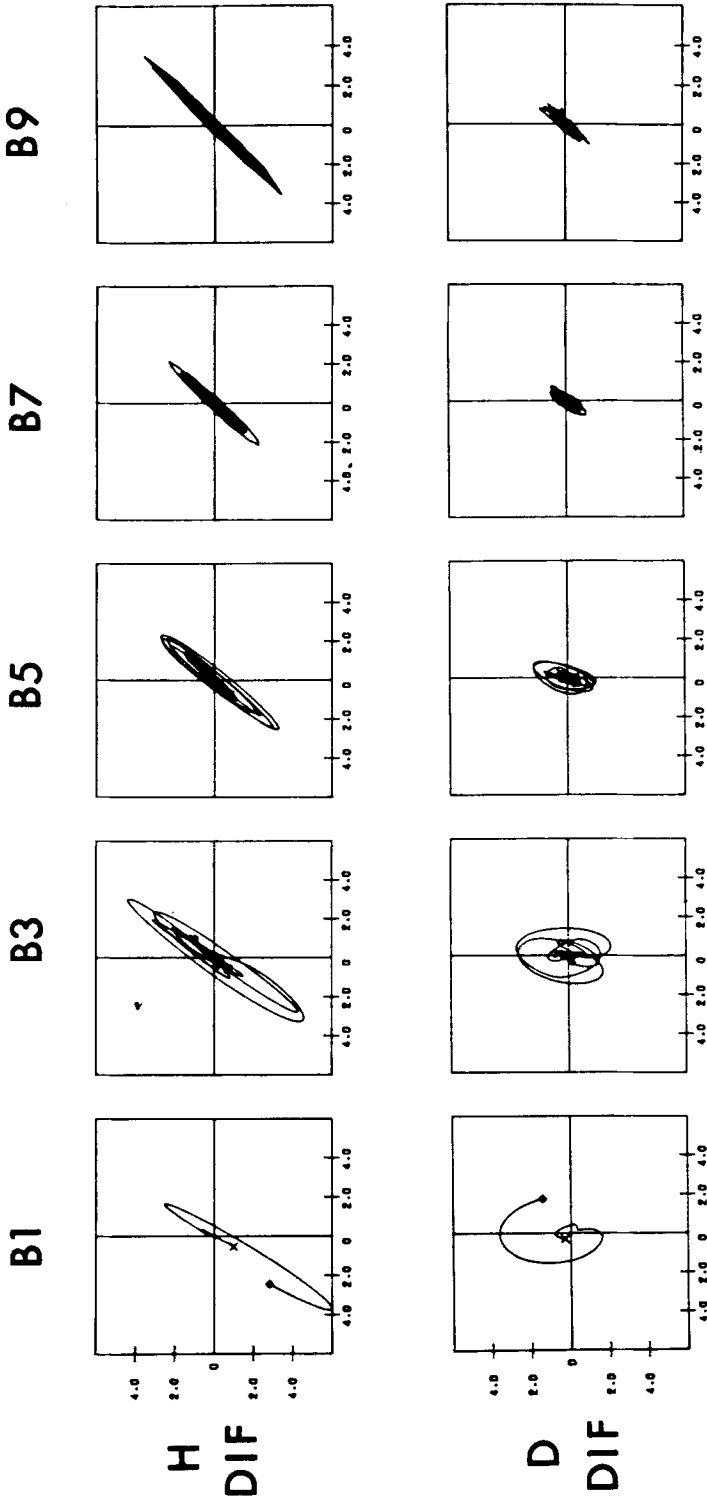

Fig. 13. The time domain hodograms of the difference horizontal magnetic fields against those at another station, upper - northward directed difference fields; lower - eastward directed difference fields [both taken from Beamish (1982)].

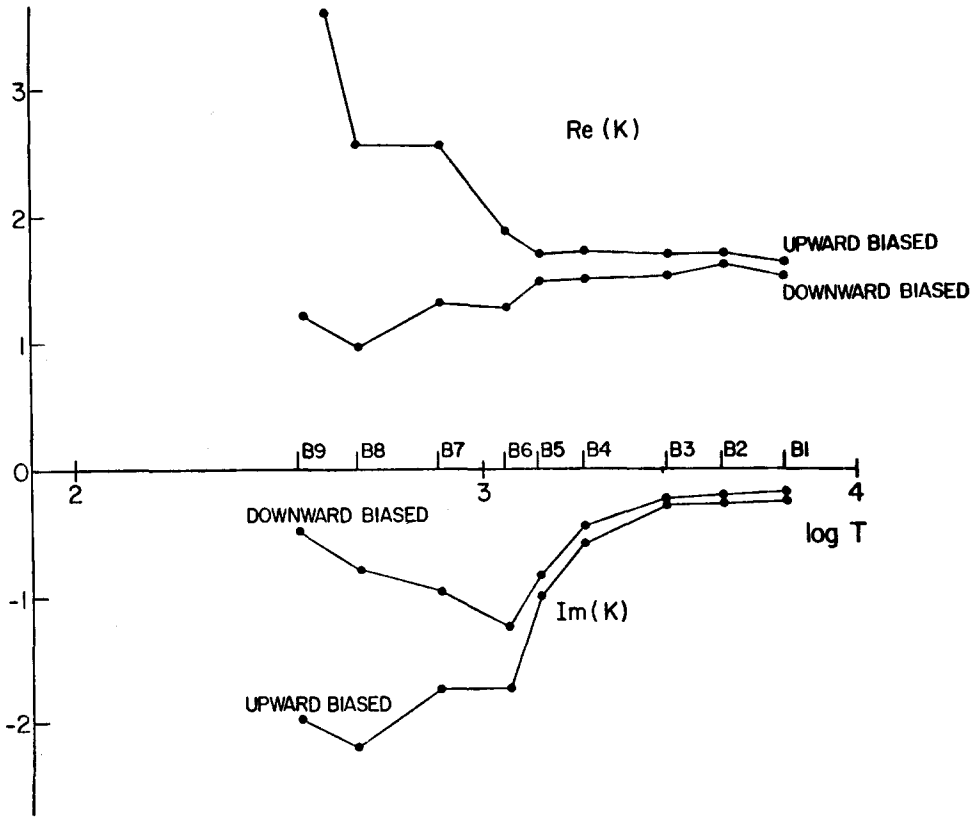

Fig. 14. The variation of the response function relating the northward directed horizontal difference magnetic field at a location to the eastward directed horizontal difference magnetic field at the same location,  $K_i$ , with period.

can be read off Figure 14). It is apparent that the difference fields appear to be far more linearly polarised than do the total fields. In Figure 13 are plotted two sets of difference fields against each other,  $h_{io}(t)$  against  $h_{jo}(t)$ , and  $d_{io}(t)$  against  $d_{jo}(t)$ , for the same 5 bands. From inspection of Figures 12 and 13, it may be concluded that the relationships defined above between the difference fields are upheld. In the frequency domain however, analysis of the three single input/single output linear systems defined by

$$H_{io}(\omega) = \Lambda_{ij} \cdot H_{jo}(\omega) \tag{32a}$$

$$D_{io}(\omega) = M_{ij} \cdot D_{jo}(\omega) \tag{32b}$$

and

$$H_{io}(\omega) = K_i \cdot D_{io}(\omega)$$

showed that the  $\Lambda_{ij}$ ,  $M_{ij}$ , and  $K_i$  are certainly not totally real, nor are they frequency independent (Figures 14 and 15 illustrate  $K_i$  and  $\Lambda_{ij}$  respectively – the ‘upward’ and

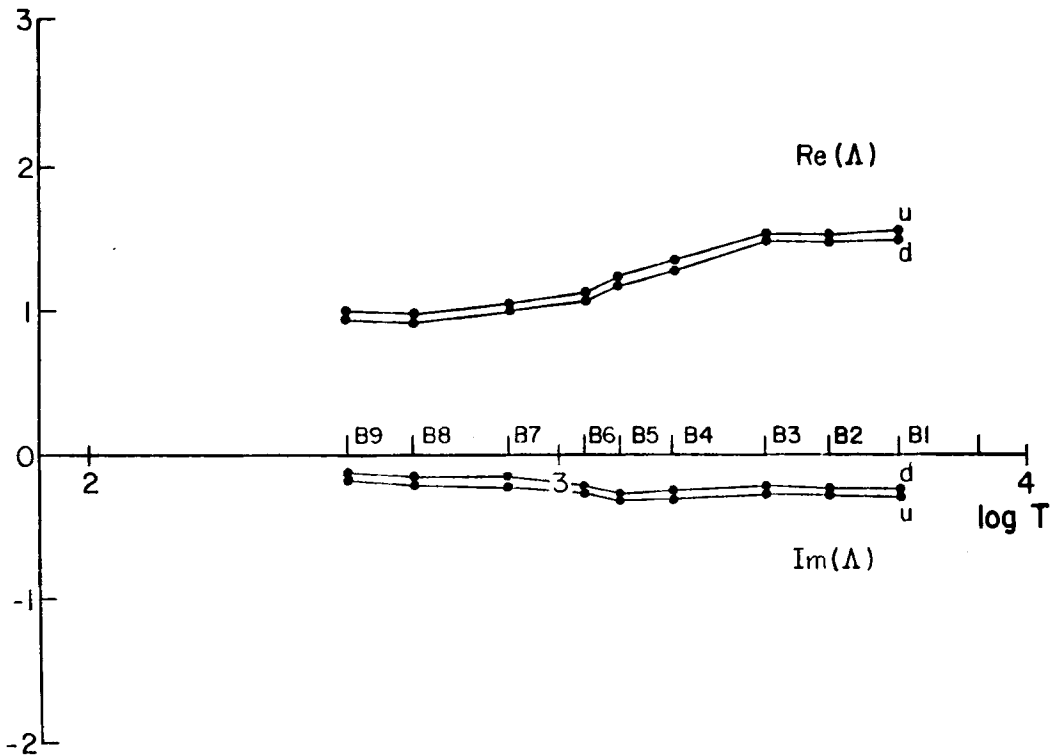

Fig. 15. The variation of the response function relating the northward directed horizontal difference magnetic field at a location to the northward directed horizontal difference magnetic field at another location,  $\Lambda_{ij}$ , with period.

'downward' biased forms  $-M_{ij}$  not shown). Beamish concludes, and this reviewer agrees with him, that mere inspection in the time domain of the relationships between the difference fields can lead to quite an erroneous and misleading interpretation, and that the relationships must be analysed by the far more powerful and objective techniques of statistical frequency analysis. Also, since the difference horizontal magnetic fields will have approximately the same form of power spectra as the total horizontal magnetic fields, i.e., increasing amplitude with increasing period such that variations of 1 hr period are, on average, 2–3 orders of magnitude greater in amplitude than those at the shorter periods of 10–50 s (see, for example, Serson, 1973, Figure 1), the unfiltered time domain hodograms will be dominated by the long period content of the difference fields. Such a dominance will mask any features contained in the shorter periods.

#### 4. Detailed Examination of Two 'Problem' Regions

##### 4.1. RHINEGRABEN

The Rhinegraben, or Rhine Valley, has probably been investigated with more thoroughness by geomagnetic induction studies than any other area on the globe.

Notwithstanding the vast amount of literature that exists on the region, there is still complete discord between two groups: those who believe that the observations can be explained by local induction in a structure whose length is such that a 2D interpretation is valid; and those who are of the opinion that the Rhinegraben 'anomaly' is an expression of ohmic flow of anomalous current between two highly conducting regions (Mediterranean to the south/North German Sedimentary Basin to the north?).

The early investigators (Haak *et al.*, 1970; Losecke, 1970; Scheelke, 1972; Haak and Reitmayr, 1974; Winter, 1973; Reitmayr, 1975) all concentrated on interpreting their observations in terms of an anomalous zone in the upper mantle. The effect of the varying sedimentary cover thickness was considered by utilising the concept of a thin inhomogeneous surface layer over a 1D substratum, as detailed by Schmucker (1971). [Note: for the Rhinegraben, the thin sheet approximation is valid down to approximately 50 s period. At shorter periods, the thickness of the graben (2.6 km) is less than three times the skin depth (average resistivity of the graben sediments is 7.5  $\Omega\text{m}$ ).] The preferred model of Reitmayr (1975) is shown in Figure 16, where the feature of interest is a postulated conducting zone (of resistivity of the order of 50  $\Omega\text{m}$ ) between 25–45 km depth below the centre of the graben.

However, Babour and Mosnier (1979) concluded from their DGS experiment that channelling in the sediments of the graben of currents induced 'elsewhere' dominated the observed responses. Also, they concluded that the deep structure, proposed by Reitmayr and others (Figure 16), is more likely linked to areas—which may be remote—in which the induction of the channelled currents occurs. This study was followed up by measurements at the top and bottom (where 'bottom' is 650 m below the surface) of a mine, located in the centre of the Rhinegraben (Babour and Mosnier, 1980). Babour and Mosnier considered the difference fields between the two mine stations,  $h_{ib}(t)$  and  $d_{ib}(t)$  (subscripts 'i' and 'b' refer to top and bottom respectively), and those between the top station and the reference station i.e.,  $h_a(t)$  and  $d_a(t)$  (here we have tacitly assumed that these difference fields are the correctly determined 'anomalous' fields). The authors studied, in the frequency domain, the relationships

$$H_{ib}(\omega) = \alpha \cdot D_{ib}(\omega)$$

and

$$H_{ib}(\omega) = \beta \cdot H_a(\omega)$$

$$D_{ib}(\omega) = \lambda \cdot D_a(\omega)$$

and found that  $\alpha$ ,  $\beta$ , and  $\lambda$  varied less than 2% in the period range 20 s to 2 hr, and that their imaginary parts were always less than 1% of their real parts. Also  $(\beta^2 + \lambda^2)$  was nearly equal to unity, i.e., the horizontal anomalous fields ( $h_a$ ,  $d_a$ ) were of the same amplitude as the vertical difference fields ( $h_{ib}$ ,  $d_{ib}$ ). These observations were considered to be explicit proof that half of the anomalous current flow is in the upper 650 m of the sediments, whilst the other half is in the depth range 650–2640 m (i.e., the basement of the graben). Thus, all the anomalous current was concluded to flow in the sedimentary

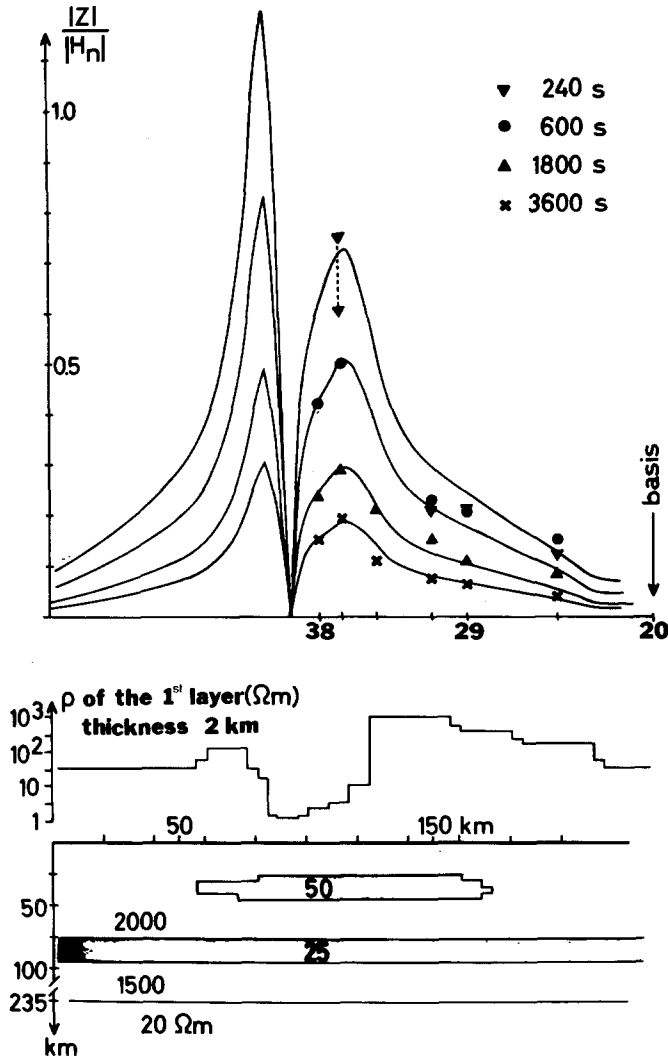

Fig. 16. Best fitting model of Reitmayr [taken from Reitmayr (1975)].

layers, and therefore no information about the deeper structure should be possible from geomagnetic measurements in the period range 20 s to 2 hr.

Albouy and Fabriol (1981) gave further credence to this theory when they undertook analysis of their short period (1–125 s) telluric and DGS measurements in the Rhinegraben. By considering the time domain hodograms of the telluric field and the difference horizontal magnetic fields, Albouy and Fabriol concluded that

$$\begin{aligned}
 h_{io}(t) &= k_i \cdot d_{io}(t), & d_{io}(t) &= \mu_{ij} d_{jo}(t) \\
 e_{xi}(t) &= m_i \cdot e_{yi}(t), & e_{xi}(t) &= n_{ij} \cdot e_{xj}(t)
 \end{aligned}$$

and

$$e_{x_i}(t) = o_{ij}d_{j0}(t),$$

where  $k_i$ ,  $\mu_{ij}$ ,  $m_i$ ,  $n_{ij}$ , and  $o_{ij}$  are real, frequency independent constants, were true for all times and all locations – which was taken as proof of the current channelling hypothesis. Also, Albouy and Fabriol calculated the 1D MT response for a conductivity-depth profile taken from resistivity log information in the centre of the graben (see also Babour and Mosnier 1980, Table 1), and showed that their 'E-polarisation' apparent resistivity curve was greater than that predicted by the 1D model. This discrepancy was considered to be due to the channelled conduction current flow, which dominated the induction currents by 4 : 1.

Hence, according to those believing in the 'current channelling' interpretation, there are five inescapable 'facts' which require flow by conduction currents. These are:

(i) the difference fields obey Equations (30a), (30b), and (30c) (Babour and Mosnier, 1979, 1980; Albouy and Fabriol, 1981),

(ii) the horizontal anomalous fields and the vertical difference horizontal field obey the same temporal law (Babour and Mosnier, 1980),

(iii) the value ( $h_{r_b}^2(t) + d_{r_b}^2(t)$ ) is very close to ( $h_a^2(t) + d_a^2(t)$ ) (Babour and Mosnier, 1980),

(iv) the telluric fields display a linearly polarised hodogram, which is perpendicular to the hodogram of the difference horizontal fields (Albouy and Fabriol, 1981),

(v) the theoretical apparent resistivity curve for a 1D model of the sediments and basement does not concur with the E-polarisation apparent resistivity curve (Albouy and Fabriol, 1981).

Notwithstanding that some of the above assertions regarding the frequency independence of certain parameters are highly questionable (see, for example, Beamish, 1982), it is believed by various workers that all of the above 'evidence' for 'current channelling' can, in fact, be more simply explained by induction in an elongated 3D graben-type structure.

Summers (1981, 1982) has shown that for E-polarisation mode induction in a 2D model of an embedded conductor, the phase of the anomalous horizontal magnetic field over, and close to, the anomaly is relatively small, and hence any inter-relations between difference fields, of the form described by Equations (30a) and (32a), would yield values of  $\Lambda_{ij}(\omega)$  that are almost totally real (point (i)). Also, the anomalous fields display far less dependence on frequency than do the normal fields or the total fields, hence  $\Lambda_{ij}(\omega)$  might appear frequency independent (point (i)). The observed linear polarisation of the anomalous horizontal magnetic fields, as expressed by Equation (30c), when compared to the apparent random polarisation of the normal field, was also shown by Summers (1982) to be characteristic of induction in an elongated conducting body. Also, on the centre of a conducting exposed 2D inhomogeneity, the E-field will be linearly polarised with its azimuthal direction parallel to strike, whilst the anomalous magnetic fields will be polarised perpendicular to strike (points (i) and (iv)).

Point (ii) implies that the fields observed at the top and bottom of the mine were

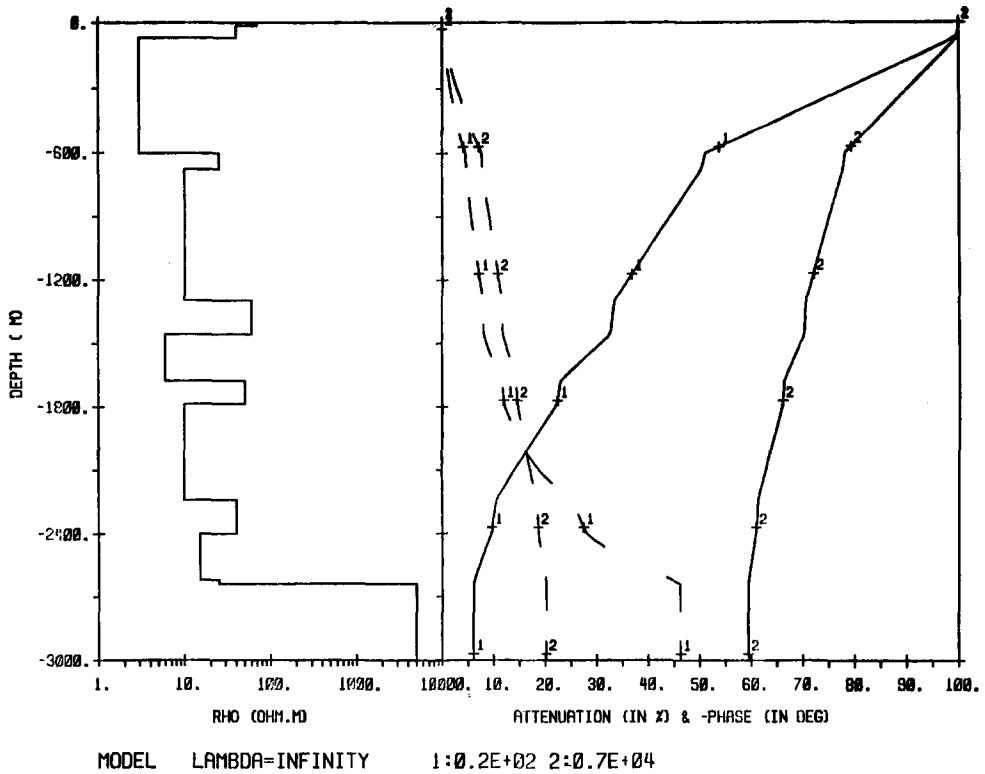

Fig. 17. The resistivity-depth profile beneath the centre of the Rhinegraben (left side of figure), and the attenuation in amplitude (full lines), and variation in phase (dashed lines), both derived analytically, of the horizontal magnetic field as it diffuses downwards through the 1D structure, at periods of 20 s (curve 1) and 2 Hr (curve 2).

substantially in phase. If, in the centre of a graben, a 1D model closely resembles the  $E$ -polarisation mode (as suggested by Reddy and Rankin, 1972), then inspection of the attenuation of the horizontal magnetic field as it diffuses downwards through a 1D model of the sediments into the poorly conducting basement would indicate how the phase of  $H_y$  varies with depth. Figure 17 illustrates the resistivity-depth profile of the centre of the Rhinegraben (taken from Babour and Mosnier, 1980), and also the attenuation in amplitude, and change in phase (both relative to the surface horizontal magnetic field), with depth at the two bounding periods of the study of Babour and Mosnier (1980) – 20 s and 7200 s (2 hr). It can be seen that at a depth of 650 m, the phase difference between the horizontal magnetic field at depth compared to that at the surface is less than  $7^\circ$  throughout the whole period range. Also, the magnetic field is appreciably attenuated at a depth of 650 m – by 50% at 20 s to 20% at 7200 s – even though the skin depth for these periods in a layer of  $7.5 \Omega\text{m}$  (the average resistivity of the sediments) is 6.5–120 km.

Dupis and Thera (1982) and Hebert (1983) undertook independently investigation of the magnetic field attenuation for a 2D model of the Rhinegraben, and both concur

with the simple 1D result that induction in the sediments can explain point (ii). Dupis and Thera also show that for their 2D model, which was based on the work of Franc de Ferriere (1979), the attenuation between the top and bottom of the mine is, at all periods studied by Babour and Mosnier, almost exactly matched by the ratio of the total  $H_y$  field observed on top of the mine to that observed at the reference station of Grand Ballon. This is because the anomalous  $H_y$  field at a location in the centre of the graben is as large as the normal field (which is another feature that is often attributed as 'evidence' for current channelling). Hence, point (iii) can be explained in terms of induction in an elongated 3D body.

Finally, Dupis and Thera, in an analysis of their own MT measurements made in the period range 0.0008 s (125 Hz) to 125 s (the two decades at the longest periods completely overlap with those of Albouy and Fabriol 1981), showed that their observations were totally in accord with induction in the known sedimentary structure of the Rhinegraben (Figure 18), thus point (v) appears to have no meaning.

In conclusion therefore we must recall our version of Occam's Razor as stated in the introduction – induction in a 2D conductivity model, which is known to be representative of the sedimentary layers in the Rhinegraben, can describe all MT, GDS, and DGS observations made without recourse to 'current channelling'.

Remembering the discussion of McKirdy's thin-sheet model (Figure 8), which may represent the Rhinegraben connecting a good conducting zone in the south (Mediterranean) to one in the north (North German Sedimentary Basin), it is clear that provided measurements are made further than about  $\delta_h$  from one of the 'ends' of the graben, a 2D interpretation of the 'E-polarisation' mode responses will give the true conductivity structure below the profile. As  $\rho_h = 1000 \Omega\text{m}$ , then at 20 s,  $\delta_h \cong 70$  km, and at 1000 s,  $\delta_h \cong 500$  km, which implies that certainly at short periods ( $< 1000$  s), the currents from such areas as the Mediterranean and the North German Sedimentary Basin have 'adjusted' such that they are in 'equilibrium' with currents that would be induced in an infinitely long 2D Rhinegraben. Whether the deep conducting layer (Figure 16), as interpreted by Reitmayr and the other earlier investigators from long period observations, is actually present, or whether it is an artifact of a 2D interpretation of a 3D problem, remains to be answered.

#### 4.2 ESKDALEMUIR ANOMALY

The Southern Uplands of Scotland is also a region that has received intense attention from the geomagnetic community within the last decade or so. Jain (1964) and Jain and Wilson (1967) interpreted MT data from the Eskdalemuir observatory in terms of a 3 layered earth, with acceptable model parameters in the ranges;  $\rho_1$ : 300–2000  $\Omega\text{m}$ ;  $\rho_2$ : 8–88  $\Omega\text{m}$ ;  $\rho_3$ :  $> 1000 \Omega\text{m}$ ;  $h_2$ : 3–40 km; and  $d_2$ : 18–44 km. Their preferred model was of a 10 km thick top layer of 1000  $\Omega\text{m}$ , underlain by a 20 km thick conducting zone of 45 km, with a basement of 2500  $\Omega\text{m}$ . Osemeikhian and Everett (1968) interpreted anomalous GDS observations in the Southern Uplands as due to a lens of conducting material within the top 100 km of the crust and upper mantle.

Edwards *et al.* (1971), in an interpretation of 10 stations located in southern Scotland



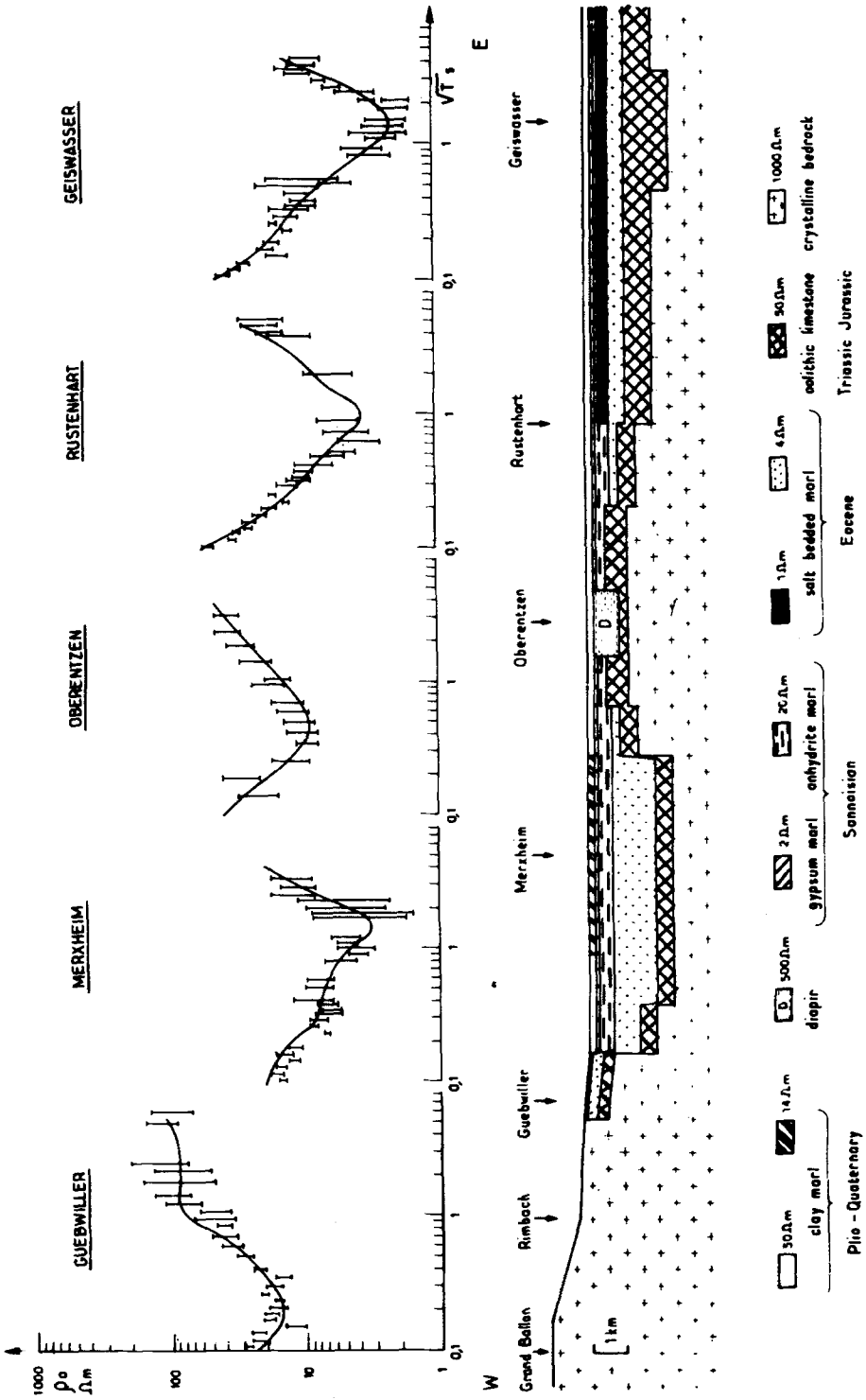

Fig. 18. The best fitting 2D model of the Rhinegraben to both short period MT and GDS data of Dupis and Thera [taken from Dupis and Thera (1982)].

and northern England, found a reversal at short periods (40 min), but not at long periods ( $> 1$  hr), of the  $H_z$  field observed at stations to the north and south of the Southern Uplands (Figure 19c). Stations north of a line running NE/SW through Eskdalemuir displayed reversed real induction vectors that pointed dominantly southeastwards at all periods, whilst a station south of this line showed reversed real vectors pointing, for most periods, northwestwards. The amplitudes at all stations, it should be noted, were highly frequency dependent (a comment by Summers (1982) to the contrary, i.e., that these GDS observations in southern Scotland are frequency

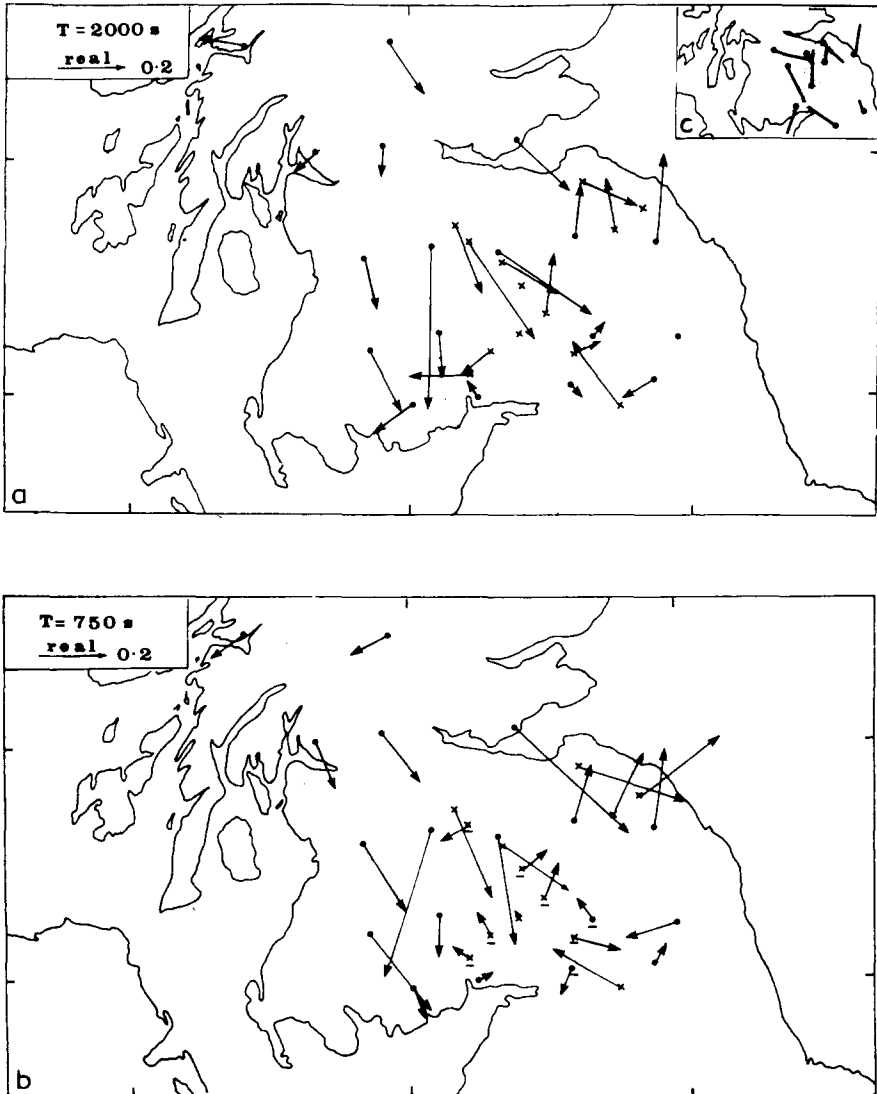

Fig. 19. The real induction vectors, observed at (a) 2000 s, and (b) 750 s, for stations occupied by Hutton and Jones [taken from Hutton and Jones (1980)].

independent, is totally incorrect). These observations were interpreted as evidence that current induced in the Atlantic Ocean branched in a loop around Britain and a loop around Ireland, with a 'short circuit' across the southern part of Scotland between the North Sea and the Irish Sea.

However, observations at pulsation periods by Green (1975) were concluded to indicate a strong conductivity contrast across the Southern Uplands Fault, with the higher conductivity rocks to the north. This result was the first indication that the simple 'Eskdalemuir anomaly', previously envisaged as an embedded conducting lens beneath the Southern Uplands at lower crustal depths, was not a correct interpretation of the lateral variation in conductivity below southern Scotland.

Following these observations, Hutton and co-workers have undertaken intensive geomagnetic studies in southern Scotland and northern England. A synoptic GDS magnetometer array study (Hutton *et al.*, 1977; Jones, 1977; Hutton and Jones, 1980; Hutton *et al.*, 1981), using Gough-Reitzel variometers, was followed up by two complete single station short period (10–1000 s) MT and GDS experiments (Jones, 1977; Jones and Hutton, 1979a, b; Hutton *et al.*, 1980; Ingham and Hutton, 1982). The long period induction vector responses, of around 2000 s and greater, were in general agreement with those of Edwards *et al.* (1971): Figure 19a. However, the shorter period vectors (40–1000 s, the vectors at 750 s are shown in Figure 19b) displayed effects which are not compatible with a single crustal conducting anomaly, and agree qualitatively with the interpretation of Green (1975) that north of the Southern Uplands Fault, in the Midland Valley of Scotland, the depth to a conducting layer is less than beneath the Southern Uplands. These GDS observations are in total accord with both the 1D (Jones and Hutton, 1979b) and the 2D (Ingham and Hutton, 1982) interpretations of the MT observations – the most acceptable 2D model is illustrated in Figure 20.

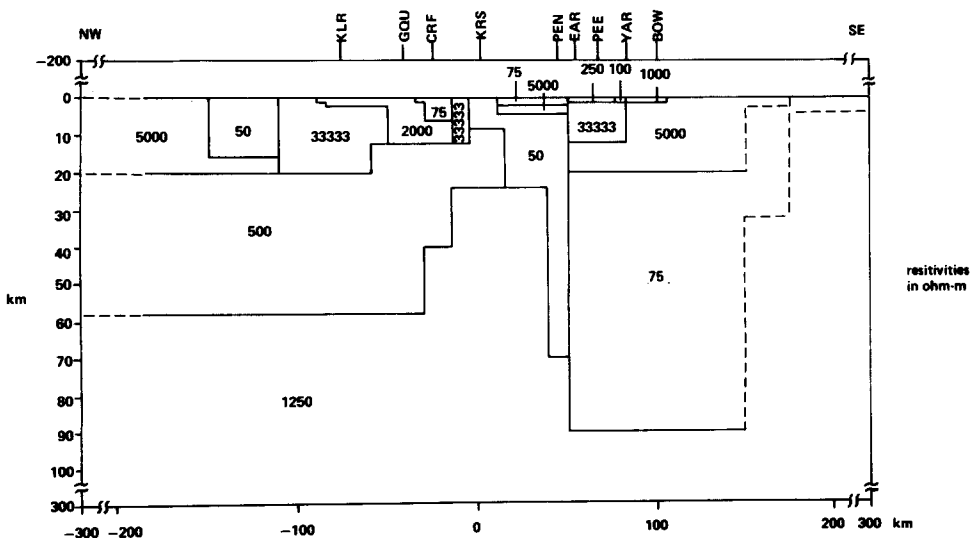

Fig. 20. The best fitting 2D model of southern Scotland [taken from Ingham and Hutton (1982)].

Although the model may appear to be, perhaps, overly complex, it was shown by Ingham and Hutton (1982) to be a satisfactory explanation of the observed MT responses at periods of 60 and 540 s. However, there was found to be a difference between the  $H_z/H_y'$ , (where  $H_y'$  is the direction perpendicular to strike) ratios calculated from this model and those actually observed (Figure 21 displays this difference at a period of 300 s). On the basis of the GDS observations at PEN and PEE, to the north and south of the Southern Uplands Fault respectively, Ingham and Hutton concluded that there must be 'conduction' as well as 'induction' taking place in the Southern Uplands, i.e., that the Eskdalemuir anomaly, which is a mantle feature rather than a crustal feature as previously thought, was in fact a region which 'channelled' currents induced elsewhere as proposed earlier by Edwards *et al.* (1971). The alternative explanation, that the 2D model was not sufficiently detailed, was mentioned but not explored. Using a line current in free space analogue, Ingham and Hutton found a best fitting equivalent line current to the 300 s responses to be of 127 A current strength, at a depth of 50 km and a position of +95 km (refer to the 'x' axis in the model illustrated in Figure 20), i.e., directly in the centre of the anomalous mantle conducting region.

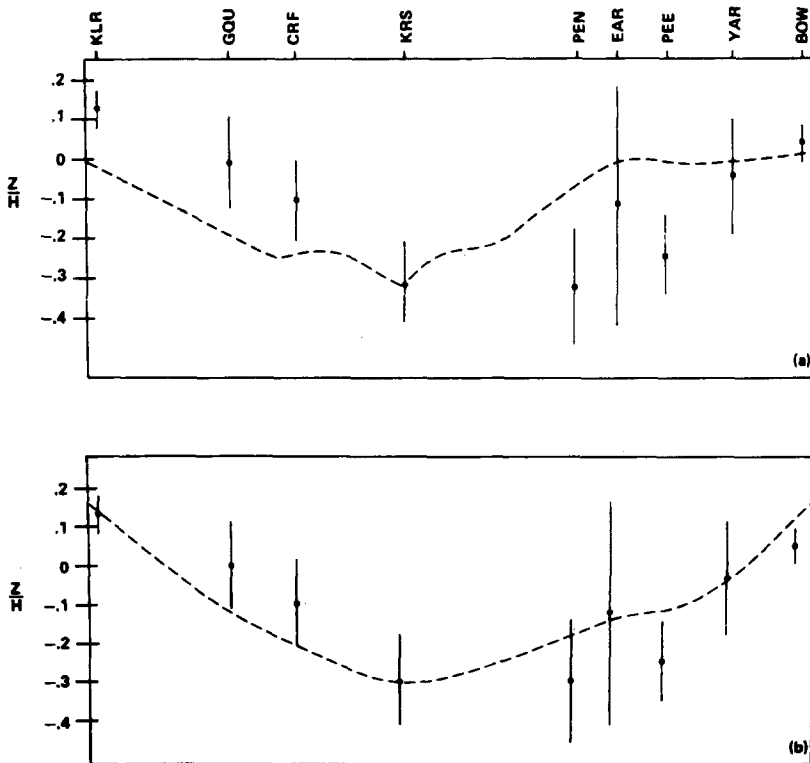

Fig. 21. The comparison of the  $H_z/H_y$  ratios, for the model illustrated in Figure 30, at 300 s to the observations (upper); and the comparison of the  $H_z/H_y$  ratios with an equivalent line current (in free space) at a depth of 50 km, at +95 km, with a current strength of 127 A.

Analogue model studies of the whole of the British Isles and Eire have been undertaken by Dosso *et al.* (1980) and Nienaber *et al.* (1981), but, because of the modelling restrictions involved, were concerned only with the relatively long periods of 33 min to 11 hr. The analogue magnetic and electric fields were contoured by Nienaber *et al.* (1981) at a period of 33 min for both the 'E-polarisation' mode (inducing magnetic field directed EW) and the 'B-polarisation' mode (inducing magnetic field NS), and certainly the  $H_z/H_y$  and the  $H_z/H_x$  maps are featureless in southern Scotland. Hence, an anomaly in conductivity must exist in the Southern Uplands – it cannot be merely a 'short-circuit' from the North Sea to the Irish Sea through a region of 'normal' continental conductivity (although a 'short-circuit' through an anomalous region of conductivity is not precluded).

Having thus established the necessity for the existence of a region of highly anomalous conductivity, the question now arises as to whether a 2D (or indeed 1D as used by Jones and Hutton) interpretation is valid given that 'channelled' currents may exist within the anomaly. The distance across the Southern Uplands along a NE/SW line through Eskdalemuir is some 160 km from coast to coast. In order to consider, at least qualitatively, the possible effects of channelling, we may appeal again to McKirdy's non-uniform thin sheet modelling of the structure shown in Figure 8. However, in this case the 'channel' should have a conductivity some two orders of magnitude less than the 'seas', and should be beneath the surface. The 'host' rock is of around  $1000 \Omega\text{m}$ , thus at 100 s period, the skin depth in the host medium is of the order of 150 km. Hence, even if the anomaly was a sea water channel, a 2D interpretation is certainly valid for modelling the MT responses in the 'E-polarisation' mode up to 100 s, and a 2D interpretation of the GDS responses would be valid at much longer periods. For a less conducting sub-surface channel, then obviously a 2D solution is valid at longer periods (1000 s?). Accordingly, the necessity for Ingham and Hutton to postulate a conduction current to describe their 300 s GDS observations is highly questionable. Also, a line current, of periodicity 300 s, embedded in a host of  $1000 \Omega\text{m}$  at a depth of 50 km, yields an electric field on the surface of the earth nowhere greater than  $10^{-5} \text{ mV/km/A}$ , i.e., for 127 amps of current flowing then  $E_x \ll 10^{-3} \text{ mV/km}$ . Hence, the contribution from a 'conducted' current to the induced electric field is extremely small. Obviously, the horizontal perpendicular-to-strike magnetic component will include a contribution due to any 'channelled' current, but for an equivalent line current with parameters as stated by Ingham and Hutton, this magnetic field will be less than  $10^{-2} \text{ nT}$  at all locations, which is well below the natural signal level in mid-latitudes at 300 s.

For the GDS responses, the  $H_z/H_y'$  ratios observed by Jones (1977) and Hutton and Jones (1980, Figure 4) at a period of 236 s are not in agreement with the observations of Ingham and Hutton at PEN and PEE (which are the stations that appear to require a 'channelled' current). For a hypothetical event polarised such that the anomaly is excited in the 'E-polarisation' mode, i.e., an inducing magnetic field directed NW/SE, Jones and Hutton find a  $H_z/H_y'$  ratio of  $-0.05$  at CAP, close to Ingham and Hutton's station PEE. This value lies directly on the 2D model curve illustrated in Figure 25.

North of the Southern Uplands Fault, the earlier work shows positive  $H_z/H_y'$  ratios whilst PEN is negative.

In conclusion therefore, at periods less than about 1000 s, a 2D model of the 'Eskdalemuir anomaly' is certainly justifiable, and the existence of any 'channelled current', i.e. current that is not in equilibrium with that in a 2D representation of the body, is highly doubtful. At longer periods, i.e., those of Edwards *et al.* (40 min) and the modelling work of Nienaber *et al.* (33 min), it is possible that 3D induction effects might become apparent, and hence become a 'problem' for a 2D interpretation, and these effects could manifest themselves as a 'DC-like' flow of anomalous current, but this has yet to be shown conclusively.

### 5. Conclusions and Suggestions for Further Work

In conclusion, it must always be borne in mind that in the real earth there are no such entities as 2D anomalies, *all* anomalies are 3D. Accordingly, the re-arrangement of lines of current density to the new 'equilibrium' is taking place in *all* anomalies and, as such, must be given due consideration in any and every interpretation. The 'problem of current channelling' has been shown to be an inadequate representation of induction in these 3D structures by 1D or 2D models. Hence, we are in desperate need of some criteria for interpretation, the most hopeful of which are those pertaining to definitions of 'adjustment distance' or 'equilibrium distance'. One such definition has been proposed here – namely that the important parameter for a 3D body is not its length-to-width ratio, but its length-to-skin-depth-in-host ratio – that is critical when interpreting data from an elongated 3D anomaly by a 2D solution.

With this point in mind, one question that might arise regarding the observations around Vancouver Island is: considering that the Strait of Georgia is such a long feature, is a 2D model satisfactory to explain the responses observed at MB and PR (see location map, Figure 2a)? Modelling the Strait of Georgia by a 10 km channel of 200 m depth of sea water (resistivity of 0.3  $\Omega\text{m}$ ), in an otherwise uniform host medium of resistivity 1500  $\Omega\text{m}$ , at a period of 250 s the normalised  $H_z$  fields, as listed in Table III, are observed. Also given in Table III are the field and 3D models values, both numerical and analogue (H. Dosso, personal communication, 1982) [note: the 2D  $H_z$  amplitudes have been normalised such that they display a value of 3.2 nT at +165 km as shown in Figure 2b for the 3D and field responses]. It is apparent that the observations at PR and MB could not be explained entirely by local induction in the Strait of George – which is not surprising because for a host of 1500  $\Omega\text{m}$  and a period of 250 s, the skin depth in the host is 300 km, i.e., of the order of the length of the Strait of Georgia (400 km), but Vancouver Island is only some 120 km wide hence  $l/\delta_h$  is less than unity (the anomaly here is Vancouver Island rather than the Strait of Georgia), which does not justify a 2D interpretation. If one tries to model Vancouver Island and the ocean as well in a 2D solution, i.e., a 2D profile taken along T5 in Figure 2a, the theoretical model yields normalised  $H_z$  values for PR and MB which are quite close to the observations (see Table III), but there is still a discrepancy. Thus, whereas a 'local' 2D model gives an

TABLE III

Normalised  $H_z$  values observed at stations PR and MB

	MB	PR
field data	7.3	8.8
3D analogue study	6.6	7.9
3D numerical study	6.8	7.7
2D numerical study of Strait of Georgia only	10.3	11.8
2D numerical study of Strait of Georgia and ocean	5.7	6.4

overestimate of  $H_z$ , because the ocean is not represented, a 'regional' 2D model gives an underestimate of  $H_z$  because it fails to include the connections between the ocean and the Strait, hence underestimating the anomalous current flowing in the Strait of Georgia. This would then be a 'problem of current channelling' and the misfit between the observations and either of the 2D models might be interpreted as a 'channelled current', or as a crustal/mantle anomaly of high conductivity beneath the Strait. (e.g., the Palk Strait?).

With regard to the studies listed in Table II, it is clear that too many workers have not sufficiently considered the effects of 'local' induction, and have, perhaps, too readily postulated 'currents' induced 'elsewhere' flowing ohmically through their region to describe their observations. This has had the rather adverse and detrimental effect that many investigators are now somewhat reluctant to interpret their data by choice of suitable 1D or 2D models. As shown in the section on numerical modelling, provided that the observational profile is conducted sufficiently distant from any 3D structure – be it the 'ends' of the body or a coastline, where 'sufficiently distant' is the appropriate 3D 'adjustment distance' – then a 2D interpretation of the '*E*-polarisation' induction mode response is valid (and, as shown by Reddy and Rankin (1972), in certain circumstances a 1D interpretation of the 2D *E*-polarisation data yields a sufficiently close approximation to the true conductivity-depth structure).

Certainly at short periods ( $< 1000$  s), a 2D interpretation of the Rhinegraben and the southern Scotland MT and GDS data have been vindicated. At long periods however ( $> 1000$  s) full 3D modelling studies need to be undertaken for both regions to indicate whether a 'problem' exists in a 2D interpretation of the 3D data.

For future work, it is of paramount importance that full statistical frequency analyses of the observations must be undertaken before remarks concerning the separation of the time and space variables are made. Mere inspection of time domain hodograms is not sufficient. Much more 3D modelling, both numerical and, where possible, analogue, should be undertaken of both simple illustrative structures, as, for example, considered by McKirdy, and of more complex and geophysically realistic ones. Finally, more theoretical consideration should be given to the problem of defining the 'adjustment distance' accurately – in order to provide experimentalists with a set of rules for the interpretation of observations.

In conclusion, I hope that my review at this 'gathering' has 'concentrated' and 'channelled' intensive thought on a problem that has, to some extent, 'deflected' and 'deviated' our understanding of electromagnetic induction in the earth.

### Acknowledgements

The reviewer wishes to acknowledge with profuse thanks all those who so kindly replied to his circular canvassing for views on 'the problem of current channelling' – however, those whose views are not represented should in no way feel slighted, keeping to within a reasonable size for this review was itself no minor problem. Also, the reviewer expresses his deep gratitude to various members of the Geophysics Laboratory of the University of Toronto, for endless discussions on this most interesting of topics, in particular Professors R. C. Bailey, R. N. Edwards, and G. D. Garland, none of whom however should be held at all responsible for this work.

### References

- Alabi, A. O., Camfield, P. A., and Gough, D. I.: 1975, 'The North American Central Plains Anomaly', *Geophys. J. R. Astr. Soc.* **43**, 815–834.
- Albouy, Y. and Fabriol, H.: 1981, 'Telluric Measurements and Differential Geomagnetic Soundings in the Rhinegraben (period range: 1–125 s)', *Geophys. J. R. Astr. Soc.* **65**, 91–101.
- Babour, K. and Mosnier, J.: 1977, 'Differential Geomagnetic Sounding', *Geophysics* **42**, 66–76.
- Babour, K. and Mosnier, J.: 1979, 'Differential Geomagnetic Sounding in the Rhinegraben', *Geophys. J. R. Astr. Soc.* **58**, 135–144.
- Babour, K. and Mosnier, J.: 1980, 'Direct Determination of the Characteristics of the Currents Responsible for the Geomagnetic Anomaly of the Rhinegraben', *Geophys. J. R. Astr. Soc.* **60**, 327–331.
- Babour, K., Mosnier, J., Daignieres, M., Vasseur, G., Le Mouel, J. L., and Rossignol, J. C.: 1976, 'A Geomagnetic Variation Anomaly in the Northern Pyrenees', *Geophys. J. R. Astr. Soc.* **45**, 583–600.
- Bailey, R. C. and Edwards, R. N.: 1976, 'The Effect of Source Field Polarisation on Geomagnetic Anomalies in the British Isles', *Geophys. J. R. Astr. Soc.* **45**, 97–104.
- Bailey, R. C., Edwards, R. N., Garland, G. D., Kurtz, R., and Pitcher, D. H., 1974, 'Electrical Conductivity Studies over a Tectonically Active Area in Eastern Canada', *J. Geomagn. Geoelectr.* **26**, 125–146.
- Beamish, D.: 1982, 'A Comparison of Time and Frequency Domain Geomagnetic Sounding', *Geophys. J. R. Astr. Soc.*, **73**, 689–704.
- Berdichevsky, M. N. and Dmitriev, V. I.: 1976, 'Distortion of Magnetic and Electric Fields by Near-Surface Lateral Inhomogeneities', *Acta. Geodaet., Geophys. et Montanist. Acad. Sci. Hung.*, **11**, 447–483.
- Booker, J. R. and Hensel, E. G.: 1981, *A Channelled Electric Current Driven into the North-West United States by the Geometry of the Coastline*, Presented at IAGA General Assembly, Edinburgh, August 3–15.
- Camfield, P. A., Gough, D. I., and Poraht, H.: 1971, 'Magnetometer Array Studies in the Northwestern United States and Southwestern Canada', *Geophys. J. R. Astr. Soc.* **22**, 201–222.
- Chan, G. H., Dosso, H. W., and Law, L. K.: 1981, 'An Analogue Model Study of Electromagnetic Induction for Cape and Bay Coastlines', *Phys. Earth Planet. Inter.* **25**, 167–176.
- Dawson, T. W. and Weaver, J. T.: 1979, 'Three-Dimensional Induction in a Nonuniform Thin Sheet at the Surface of a Uniformly Conducting Earth', *Geophys. J. R. Astr. Soc.* **59**, 445–462.
- Dawson, T. W., Weaver, J. T., and Raval, U.: 1982, 'B-Polarization Induction in Two Generalised Thin Sheets at the Surface of a Conducting Half-Space', *Geophys. J. R. Astr. Soc.* **69**, 209–234.
- DeLaurier, J. M., Law, L. K., Niblett, E. R., and Plet, F. C.: 1974, Geomagnetic Variation Anomalies in the Canadian Arctic II. Mould Bay Anomaly', *J. Geomagn. Geoelectr.* **26**, 223–245.
- DeLaurier, J. M., Niblett, F., Plet, F., and Camfield, P. A.: 1980, 'Geomagnetic Depth Sounding over the Central Arctic Islands, Canada', *Can. J. Earth Sci.* **17**, 1642–1652.



- DeLaurier, J. M., Plet, F. C., and Drury, M. J.: 1981, 'A Geomagnetic Depth Sounding Profile Across the Northern Yukon and the MacKenzie Delta Region, Canada', *Can. J. Earth Sci.* **18**, 1092-1100.
- Dobrovolskaya, M. A. and Kovtun, A. A., 1976. 'Behaviour of Magnetotelluric Field on the Surface of Horizontal Inhomogeneous Strata (Model Experiments)', in A. Adam (ed.), *Geoelectric and Geothermal Studies (East-Central Europe, Soviet Asia)*, KAPG Geophysical Monograph, Akademiai Kiado, Budapest, pp. 245-255.
- Dosso, H. W., Nienaber, W., and Hutton, V. R. S.: 1980, 'An Analogue Model Study of Electromagnetic Induction in the British Isles Region', *Phys. Earth Planet. Inter.* **22**, 68-85.
- Dragert, H.: 1973, 'A Transfer Function Analysis of a Geomagnetic Depth Sounding Profile Across Central British Columbia', *Can. J. Earth Sci.* **10**, 1089-1098.
- Drury, M. J. and Niblett, E. R.: 1980, 'Buried Ocean Crust and Continental Crust Geomagnetic Induction Anomalies: A Possible Association', *Can. J. Earth Sci.* **17**, 961-967.
- Dupis, A. and Thera, A. L.: 1982, 'Natural Electromagnetism in the Rhine Graben', *Geophys. J. R. Astr. Soc.* **68**, 545-557.
- Dyck, A. V. and Garland, G. D.: 1969, 'A Conductivity Model of Certain Features of the Alert Anomaly in Geomagnetic Variations', *Can. J. Earth Sci.* **6**, 513-516.
- Edwards, R. N.: 1974, 'The Magnetometric Resistivity Method and Its Applications to the Mapping of a Fault', *Can. J. Earth Sci.* **11**, 1136-1156.
- Edwards, R. N., Law, L. K., and White, A.: 1971, 'Geomagnetic Variations in the British Isles and Their Relation to Electrical Currents in the Ocean and Shallow Seas', *Phil. Trans. Roy. Soc. London*, **270**, 289-323.
- Edwards, R. N. and Nabighian, M. N.: 1981, 'Extensions of the Magnetometric Resistivity (MMR) Method', *Geophysics* **46**, 459-460.
- Fowler, R. A., Kotick, B. J., and Elliot, R. D.: 1967, 'Polarisation Analysis of Natural and Artificially Induced Geomagnetic Micropulsations', *J. Geophys. Res.* **72**, 2871-2883.
- Franc de Ferriere, D.: 1979, 'Les resistivites electriques sedimentaires dans le Fosse Rhenan en relation avec la geothermie', Ph. D., University of Paris.
- Gough, D. I.: 1973, 'The Interpretation of Magnetometer Array Studies', *Geophys. J. R. Astr. Soc.* **35**, 85-98.
- Green, C. A.: 1975, 'An Induction Study at Micropulsation Periods in the British Isles', *Geophys. J. R. Astr. Soc.* **40**, 225-240.
- Haak, V.: 1978, *Interpretations-Verfahren für die Magnetotellurik unter besonderer Berücksichtigung lateral variierender elektrischer Leitfähigkeit im Erdinnern und eines raumlichinhomogenen Magnetfelds*, München Ak.-Abh. math.-rat., 158, München.
- Haak, V. and Reitmayr, G.: 1974, 'The Distribution of Electrical Resistivity in the Rhinegraben Area Determined by Telluric and Magnetotelluric Methods', in J. H. Illies and K. Fuchs, (eds.), *Approaches to Taphrogenesis*, Schweitzerbart, Stuttgart, pp. 366-369.
- Haak, V., Sengpiel, K.-P., Berkold, A., and Greinwald, S.: 1970, 'The Telluric Method: Results and Measurements Along a Profile Across the Rhinegraben Between Stuttgart and Kaiserslautern', in J. H. Illies and St. Mueller, (eds.), *Graben Problems*, Schweitzerbart, Stuttgart, pp. 235-238.
- Handa, S. and Camfield, P. A.: 1982, *Magnetic Variation Study in North Central Saskatchewan*, Paper presented at C.G.U., York University, May 10-12.
- Hempfling, R. and Schmucker, U.: 1978, *Local Distortion of Near-Surface Currents Induced by Sq*, Paper presented at 4th. Workshop on Electromagnetic Induction, Murnau, Federal Republic of Germany, September 7-13.
- Hebert, D.: 1983, 'The Frequency Response of the Horizontal Magnetic Field for a Conductive Channel', *Geophys. J. R. Astr. Soc.*, **73**, 577-580.
- Hermance, J. F.: 1982, 'The Asymptotic Response of Three-Dimensional Basin Offsets to Magnetotelluric Fields at Long Periods: The Effects of Current Channelling', *Geophysics* **47**, 1562-1573.
- Hewson-Browne, R. C. and Kendall, P. C.: 1976, 'Magnetotelluric Modelling and Inversion in Three-Dimensions', *Acta Geodæt., Geophys. et Montanist. Acad. Sci. Hung.* **11**, 427-446.
- Hohmann, G. W.: 1983, 'Three-Dimensional EM Interpretation', *Geophys. Surveys*, **6**, 27-53 (this issue).
- Hutton, V. R. S. and Jones, A. G.: 1980, 'Magnetovariational and Magnetotelluric Investigations in S. Scotland', in U. Schmucker (ed.), *Electromagnetic Induction in the Earth and Moon*, AEPS-9, Centr. Acad. Publ. Japan, Tokio and D. Reidel Publ. Co., Dordrecht, Holland. Suppl. Issue J. Geomagn. Geoelectr., pp. 141-150.
- Hutton, V. R. S., Sik, J., and Gough, D. I.: 1977, 'Electrical Conductivity and Tectonics in Southern Scotland', *Nature* **266**, 617-620.

- Hutton, V. R. S., Ingham, M. R., and Mbipom, E. W.: 1980, 'An Electrical Model of the Crust and Upper Mantle in Scotland', *Nature* **287**, 30–33.
- Hutton, V. R. S., Dawes, G., Ingham, M., Kirkwood, S., Mbipom, E. W., and Sik, J.: 1981, 'Recent Studies of Time Variations of Natural Electromagnetic Fields in Scotland', *Phys. Earth Planet. Inter.* **24**, 66–87.
- Ingham, M. R. and Hutton, V. R. S.: 1982, 'Crustal and Upper Mantle Electrical Conductivity Structure in Southern Scotland', *Geophys. J. R. Astr. Soc.* **68**, 579–594.
- Jain, S.: 1964, Electrical Conductivity of the Crust and Upper Mantle at Eskdalemuir, Southern Scotland', *Nature* **203**, 631–632.
- Jain, S. and Wislon, C. D. V.: 1967, 'Magnetotelluric Investigations in the Irish Sea and Southern Scotland', *Geophys. J. R. Astr. Soc.* **12**, 165–180.
- Jones, A. G.: 1977, *Geomagnetic Induction Studies in Southern Scotland*; Ph. D. thesis, Dept. of Geophys., University of Edinburgh, Scotland.
- Jones, A. G. and Hutton, R.: 1979a, 'A Multi-Station Magnetotelluric Study in Southern Scotland – I. Fieldwork, Data Analysis and Results', *Geophys. J. R. Astr. Soc.* **56**, 329–349.
- Jones, A. G. and Hutton, R.: 1979b, 'A Multi-Station Magnetotelluric Study in Southern Scotland – II. Monte-Carlo Inversion of the Data and Its Geophysical and Tectonic Implications', *Geophys. J. R. Astr. Soc.* **56**, 351–368.
- Jones, A. G. and Weaver, J.: 1981, *Induction by Uniform and Non-Uniform Source Fields over Northern Scandinavia: Field Data and Numerical Modelling*, Paper presented at 4th IAGA Assembly, Edinburgh, Scotland, August 3–15.
- Jones, F. W.: 1973, 'Induction in Laterally Non-Uniform Conductors: Theory and Numerical Models', *Phys. Earth Planet. Inter.* **7**, 282–293.
- Jones, F. W. and Price, A. T.: 1970, 'The Perturbations of Alternating Geomagnetic Fields by Conducting Anomalies', *Geophys. J. R. Astr. Soc.*, **20**, 317–334.
- Jones, F. W. and Pascoe, L. J.: 1973, 'The perturbation of Alternating Geomagnetic Fields by Three-Dimensional Structures', *Geophys. J. R. Astr. Soc.* **32**, 133–154.
- Jones, F. W. and Price, A. T.: 1973, 'Reply to Discussion on 'Geomagnetic effects of sloping and shelving discontinuities of earth conductivity'', *Geophysics* **37**, 541–542.
- Kemmerle, K.: 1977, 'On the Influence of Local Anomalies of Conductivity at the Earth's Surface on Magnetotelluric Data', *Acta Geodaet., Geophys. et Montanist. Acad. Sci. Hung.* **12**, 177–181.
- Kirkwood, S. C., Hutton, V. R. S., and Sik, J.: 1981, 'A Geomagnetic Study of the Great Glen Fault', *Geophys. J. R. Astr. Soc.*, **66**, 481–490.
- Larsen, J. C.: 1977, 'Removal of Local Surface Conductivity Effects from Low Frequency Mantle Response Curves', *Acta Geodaet., Geophys. et Montanist. Acad. Sci. Hung.* **12**, 183–186.
- Lee, T.-C.: 1977, 'Telluric Anomalies Caused by Shallow Structures: Ellipsoidal Approximations', *Geophysics* **42**, 97–102.
- Le Borgne, E. and Le Mouel, J. L.: 1975, 'A Conductivity Anomaly in the Western Mediterranean', *Geophys. J. R. Astr. Soc.* **43**, 939–955.
- Le Mouel, J. L. and Menvielle, M.: 1982, 'Geomagnetic Variation Anomalies and Deflection of Telluric Currents', *Geophys. J. R. Astr. Soc.*, **68**, 575–587.
- Lienert, B. R.: 1979, 'Crustal Electrical Conductivities along the Eastern Flank of the Sierra Nevadas', *Geophysics*, **44**, 1830–1845.
- Lilley, F. E. M. and Arora, B. R.: 1982, 'The Sign Convention for Quadrature Parkinson Arrows in Geomagnetic Induction Studies', *Rev. Geophys. Space Phys.*, **20**, 513–518.
- Losecke, W.: 1970, 'Ergebnisse magnetotellurischer Messungen bei Speyer', in J. H. Illies and St. Mueller (eds.), 'Graben Problems', Schweitzerbart, Stuttgart, pp. 242–244.
- Menvielle, M. and Rossignol, J.-C.: 1982, 'Consequences tectoniques de l'existence d'une anomalie de conductive electrique au Nord du Maroc', *Can. J. Earth Sci.* **19**, 1507–1517.
- Niblett, E. R., DeLaurier, J. M., Law, L. K., and Plet, F. C.: 1974, 'Geomagnetic Variation Anomalies in the Canadian Arctic I. Ellesmere island and Lincoln Sea', *J. Geomagn. Geoelectr.* **26**, 203–221.
- Nienaber, W., Dosso, H. W., and Hutton, V. R. S.: 1981, 'Electromagnetic Induction in the British Isles Region: Analogue Model and Field Station Results', *Phys. Earth Planet. Inter.* **27**, 122–132.
- Nienaber, W., Dosso, H. W., Law, L. K., Jones, F. W., and Ramaswamy, V.: 1976, 'An Analogue Model Study of Electromagnetic Induction for Island-Continent Ocean Channels', *Phys. Earth Planet. Inter.* **13**, 169–183.
- Nienaber, W., Dosso, H. W., Law, L. K., Jones, F. W., and Ramaswamy, V.: 1977, 'An Analogue Model Study of Electromagnetic Induction for Island-Continent Ocean Channels for H Polarisation', *Phys. Earth Planet. Inter.* **15**, 69–76.

- Nityananda, N., Agarwal, A. K., and Singh, B. P.: 1977, 'Induction at Shorts Periods in the Horizontal Field Variations in the Indian Peninsular', *Phys. Earth Planet. Inter.* **15**, 5-9.
- Osemekhian, J. E. A. and Everett, J. E.: 1968, 'Anomalous Magnetic Variations in S. W. Scotland', *Geophys. J. R. Astr. Soc.* **15**, 361-366.
- Porath, H. and Dziewonski, A.: 1971, 'Crustal Resistivity Anomalies from Geomagnetic Deep Sounding Studies', *Rev. Geophys. Space Phys.* **9**, 891-915.
- Porath, H., Gough, D. I., and Camfield, P. A.: 1971, 'Conductive Structures in the Northwestern United States and South-West Canada', *Geophys. J. R. Astr. Soc.* **23**, 387-398.
- Praus, O., DeLaurier, J., and Law, L. K.: 1971, 'The Extension of the Alert Geomagnetic Anomaly Through Northern Ellesmere Island', *Can. J. Earth Sci.* **8**, 50-64.
- Price, A. T.: 1964, 'A Note on the Interpretation of Magnetic Variations and Magnetotelluric Data', *J. Geomagn. Geoelectr.* **15**, 241-248.
- Price, A. T.: 1973, 'The Theory of Geomagnetic Induction', *Phys. Earth Planet. Inter.* **7**, 227-233.
- Rajaram, M., Singh, B. P., Nityananda, N., and Agarwal, A. K.: 1979, 'Effect of the Presence of a Conducting Channel between India and Sri Lanka Island on the Features of the Equatorial Electrojet', *Geophys. J. R. Astr. Soc.* **56**, 127-138.
- Ramaswamy, V., Nienaber, W., Dosso, H. W., Jones, F. W., and Law, L. K.: 1977, 'Comments on the Numerical and Analogue Model Results for Electromagnetic Induction for an Island Situated Near a Coastline', *Phys. Earth Planet. Inter.* **14**, 28-30.
- Ramaswamy, V., Jones, F. W., Dosso, H. W., and Nienaber, W.: 1980, 'A Comparison of Numerical, Analogue Model and Field-Station Vertical Magnetic Fields for the Vancouver Island Region', *Phys. Earth Planet. Inter.* **22**, 60-67.
- Ranganayaki, R. P. and Madden, T. R.: 1980, 'Generalized Thin Sheet Analysis in Magnetotellurics: An Extension of Price's Analysis', *Geophys. J. R. Astr. Soc.* **60**, 445-457.
- Reddy, I. K. and Rankin, D.: 1972, 'On the Interpretation of Magnetotelluric Data in the Plains of Alberta', *Can. J. Earth Sci.* **9**, 514-527.
- Rikitake, T. and Whitham, K.: 1964, 'Interpretation of the Alert Anomaly in Geomagnetic Variations', *Can. J. Earth Sci.* **1**, 35-62.
- Reitmayr, G.: 1975, 'An Anomaly of the Upper Mantle Below the Rhinegraben, Studied by the Inductive Response of Natural Electromagnetic Fields', *J. Geophys.* **41**, 651-658.
- Scheelke, I.: 1974, *Elektromagnetische Induktion im Erdinnern studiert am Rhinegraben*, Diss., Geowiss. Fak., University of Munich.
- Schmucker, U.: 1970, 'Anomalies of Geomagnetic Variations in the Southwestern United States', *Bull. Scripps Inst. Oceanogr.*, Univ. Calif. Press, **13**.
- Schmucker, U.: 1971, 'Interpretation of Induction Anomalies above Nonuniform Surface Layers', *Geophysics* **36**, 156-165.
- Serson, P. H.: 1973, 'Instrumentation for Induction Studies on Land', *Phys. Earth Planet. Inter.* **7**, 313-322.
- Singh, B. P., Nityananda, N., and Agarwal, A. K.: 1977, 'Induced Magnetic Field Variations in the Indian Peninsular', *Acta Geodaet., Geophys. et Montanist. Acad. Sci. Hung.* **12**, 65-72.
- Summers, D. M.: 1981, 'Interpreting the Magnetic Fields Associated with Two-Dimensional Induction Anomalies', *Geophys. J. R. Astr. Soc.* **65**, 535-552.
- Summers, D. M.: 1982, 'On the Frequency Response of Geomagnetic Induction Anomalies', *Geophys. J. R. Astr. Soc.* **70**, 487-502.
- Thakur, H. K., Mahashabde, M. V., Arora, B. R., Singh, B. P., Srivastava, B. J., and Prasad, S. N.: 1981, 'Anomalies in Geomagnetic Variations on Peninsular India Near Palk Strait', *Geophys. Res. Lett.* **8**, 947-950.
- Ting, S. C. and Hohmann, G. W.: 1981, 'Integral Equation Modelling of Three-Dimensional Magnetotelluric Response', *Geophysics* **46**, 182-197.
- Vasseur, G. and Weidelt, P.: 1977, 'Bimodal Electromagnetic Induction in Nonuniform Thin Sheets with an Application to the Northern Pyrenean Induction Anomaly', *Geophys. J. R. Astr. Soc.* **51**, 669-690.
- Vasseur, G., Babour, K., Menvielle, M., and Rossignol, J. C.: 1977, 'The Geomagnetic Variation Anomaly in the Northern Pyrenees: Study of the Temporal Variation', *Geophys. J. R. Astr. Soc.* **49**, 593-607.
- Weaver, J. T.: 1982, 'Regional Induction in Scotland: An Example of Three-Dimensional Numerical Modelling Using the Thin Sheet Approximation', *Phys. Earth Planet. Inter.* **28**, 161-180.
- Weidelt, P.: 1975, 'Electromagnetic Induction in Three-Dimensional Structures', *J. Geophys.* **41**, 85-109.
- Weidelt, P.: 1977, 'Numerical Study of a Conductive Channelling Effect', *Acta Geodaet., Geophys. et Montanist. Acad. Sci. Hung.* **12**, 195-205.

- Whitham, K. and Andersen, F.: 1965, 'Magneto-Telluric Experiments in Northern Ellesmere Island', *Geophys. J. R. Astr. Soc.* **10**, 317-345.
- Wilhelm, J. and Friis-Christensen, E.: 1974, 'The Igdlorssuit Geomagnetic Variation Anomaly in the Rift-Fault Zone of Northern West Greenland', *J. Geomagn. Geoelectr.* **26**, 173-189.
- Winter, R.: 1973, *Der Oberheingraben als Anomalie elektrischen leitfähigkeit untersucht mit Methoden der Erdmagnetischen Tiefensondierung*, Diss., Math.-Naturwiss. Fak., University of Göttingen.
- Woods, D. V. and Lilley, F. E. M.: 1980, 'Anomalous Geomagnetic Variations and the Concentration of Telluric Currents in South-West Queensland, Australia', *Geophys. J. R. Astr. Soc.* **62**, 675-689.